

*FRENIC-Lift*

# Multi-function Keypad "TP-G1-□LS"

---

## **CAUTION**

Thank you for purchasing our Multi-function Keypad TP-G1-CLS / TP-G1-ELS.

- This product is designed to remotely control the FRENIC-Lift series of inverters. Read through this instruction manual and the FRENIC-Lift Instruction Manual, and be familiar with the handling procedure for correct use.
- Improper handling blocks correct operation or causes a short life or failure.
- Deliver this manual to the end user of the product. Keep this manual in a safe place until the multi-function keypad is discarded.
- For the usage of inverters and optional equipment, refer to the instruction manuals prepared for the FRENIC-Lift series of inverters and its optional equipment.

Copyright © 2005 – 2007 Fuji Electric FA Components & Systems Co., Ltd.

All rights reserved.

No part of this publication may be reproduced or copied without prior written permission from Fuji Electric FA Components & Systems Co., Ltd.

All products and company names mentioned in this manual are trademarks or registered trademarks of their respective holders.

The information contained herein is subject to change without prior notice for improvement.

# Preface

Thank you for purchasing our multi-function keypad TP-G1-CLS / TP-G1-ELS.

By installing the multi-function keypad directly on a FRENIC-Lift as an attached keypad or connecting them together using an optional remote operation extension cable (CB-5S, CB-3S, or CB-1S, depending on the distance), you can operate the inverter locally or remotely. In either mode, you can run and stop the motor, monitor the running status, and set the function codes. In addition, you can perform "data copying": You can read function code data from an inverter, copy (write) it into another inverter, or verify it.

Before installing and using the multi-function keypad, read through this manual in conjunction with the FRENIC-Lift Instruction Manual (INR-SI47-1038-E) and familiarize yourself with its proper use. Improper use may prevent normal operation or cause a failure or reduced life of the inverter.

The LCD on the multi-function keypad may display each function code name as "FUNCTION." For the proper function code name refer to the FRENIC-Lift Instruction Manual (INR-SI47-1038-E) and the FRENIC-Lift Reference Manual (INR-SI47-1068-E).

## Related Publications

Listed below are other publications on the FRENIC-Lift to be consulted in conjunction with this manual as necessary.

- FRENIC-Lift Instruction Manual (INR-SI47-1038-E)
- FRENIC-Lift Reference Manual (INR-SI47-1068-E)

The materials are subject to change without notice. Be sure to obtain the latest editions for use.

## ■ About the ROM version of multi-function keypad



Please read manual (INR-SI47-1056-E) when ROM version of a multi-function keypad is 8510. It might be different from the content of the description of this manual.

Please refer to this Manual 3.4.6 Reading maintenance information Menu #5 "Maintenance Information" for the confirm method of ROM version of multi-function keypad.

## ■ Safety precautions

Read this manual thoroughly before proceeding with installation, connections (wiring), operation, or maintenance and inspection. Ensure you have sound knowledge of the device and familiarize yourself with all safety information and precautions before proceeding to operate the inverter.

Safety precautions are classified into the following two categories in this manual.

 <b>WARNING</b>	Failure to heed the information indicated by this symbol may lead to dangerous conditions, possibly resulting in death or serious bodily injuries.
 <b>CAUTION</b>	Failure to heed the information indicated by this symbol may lead to dangerous conditions, possibly resulting in minor or light bodily injuries and/or substantial property damage.

Failure to heed the information contained under the CAUTION title can also result in serious consequences. These safety precautions are of utmost importance and must be observed at all times.

## Operation

### **WARNING**

- Be sure to install the terminal block cover and the front cover before turning the power on. Do not remove the covers while power is applied.  
**Otherwise electric shock could occur.**
- Do not operate switches/buttons with wet hands.  
**Doing so could cause electric shock.**
- If the retry function has been selected, the inverter may automatically restart and drive the motor depending on the cause of tripping. Design the machinery or equipment so that human safety is ensured after restarting.
- Never make an alarm reset with the operation signal being on. Doing so will suddenly restart the inverter. Ensure that the operation signal is turned off beforehand.  
**Otherwise an accident could occur.**
- If you set the function codes wrongly or without completely understanding this instruction manual, the FRENIC-Lift Instruction Manual (INR-SI47-1038-E) and the FRENIC-Lift Reference Manual (INR-SI47-1068-E), the motor may rotate with a torque or at a speed not permitted for the machine.  
**An accident or injuries could occur.**
- Do not touch the inverter terminals while the power is applied to the inverter even if the inverter stops.  
**Doing so could cause electric shock.**

## Wiring

### **WARNING**

- Do not operate the switch with wet hands.  
**Doing so could cause electric shock.**
- Before opening the cover of the inverter to install the multi-function keypad, turn the power off and wait for at least five minutes. Further, make sure that the LED monitor is turned off, the charger indicator is off, and the DC link bus voltage between the terminals P (+) and N (-) has dropped below the safe voltage level (+25 VDC), using a circuit tester or another appropriate instrument.  
**Otherwise electric shock could occur.**
- In general, the insulation property of the sleeve of the signal wire and that of the sheath of the signal cable are not sufficient for high voltages. Therefore, if a signal wire or cable comes into direct contact with a live part of the main circuit, the insulation may be broken, causing the signal wire to be exposed to the high voltage of the main circuit. Be sure to keep all signal wires and cables away from live parts of the main circuit.  
**Otherwise, an accident or electric shock could occur.**

## Disposal

### CAUTION

- For disposal, treat the multi-function keypad as industrial waste.  
**Otherwise injuries could occur.**

## Others

### WARNING

- Never attempt to modify the multi-function keypad or inverter.  
**Doing so could cause electric shock or injuries.**

### GENERAL PRECAUTIONS

Drawings in this manual may be illustrated without covers or safety shields for explanation of detail parts. Restore the covers and shields in the original state and observe the description in the manual before starting operation.

## How this manual is organized

This manual is made up of chapters 1 through 4

### Chapter 1 BEFORE USING THE MULTI-FUNCTION KEYPAD

This chapter describes the points to check upon delivery and lists the inverters the multi-function keypad is designed to interface with.

### Chapter 2 INSTALLATION AND INTERCONNECTION

This chapter describes how to install the multi-function keypad and how to interconnect it with an inverter.

### Chapter 3 OPERATION USING THE MULTI-FUNCTION KEYPAD

This chapter describes the operation of the inverter using the multi-function keypad. More specifically, this chapter gives an overview of the inverter's three operation modes (Running, Programming, and Alarm modes) and describes how to run and stop the inverter/motor, set function code data, monitor running status, view maintenance information and alarm data, and perform data copying.

### Chapter 4 SPECIFICATIONS

This chapter lists the general specifications such as operating environments, communication specifications and transmission specifications.

## Icons

The following icons are used throughout this manual.

 **Note** This icon indicates information which, if not heeded, can result in the product not operating to full efficiency, as well as information concerning incorrect operations and settings which can result in accidents.

 **Tip** This icon indicates information that can prove handy when performing certain settings or operations.

 This icon indicates a reference to more detailed information.

# Table of Contents

Preface .....	i	Chapter 4 .....	SPECIFICATIONS .....
■ Safety precautions.....	i	4.1 General Specifications .....	4-1
How this manual is organized .....	iii	4.2 Communication Specifications .....	4-2
		4.3 Transmission Specifications.....	4-2
<b>Chapter 1 BEFORE USING THE MULTI-FUNCTION KEYPAD .....</b>	<b>1-1</b>		
1.1 Acceptance Inspection.....	1-1		
1.2 Inverters with which the Multi-function Keypad Interfaces taka .....	1-1		
<b>Chapter 2 INSTALLATION AND INTERCONNECTION ..</b>	<b>2-1</b>		
2.1 Accessories and Parts Required for Interconnection .....	2-1		
2.2 Installing the Multi-function Keypad .....	2-2		
2.2.1 Three ways of installation/use .....	2-2		
2.2.2 Installing the multi-function keypad .....	2-3		
<b>Chapter 3 OPERATION USING THE MULTI-FUNCTION KEYPAD .....</b>	<b>3-1</b>		
3.1 Components on the Keypad .....	3-1		
3.2 Overview of Operation Modes .....	3-4		
3.3 Running Mode .....	3-5		
3.3.1 Running/stopping the motor.....	3-5		
3.3.2 Setting the reference speed (pre-ramp).....	3-7		
3.3.3 Monitoring the running status on the LED monitor .....	3-8		
3.4 Programming Mode .....	3-9		
3.4.1 Setting function codes -- Menu #1 "Data Setting" -- .....	3-10		
3.4.2 Setting up function codes quickly -- Menu #0 "Quick Setup" -- .....	3-13		
3.4.3 Checking changed function codes -- Menu #2 "Data Checking" -- .....	3-13		
3.4.4 Monitoring the running status -- Menu #3 "Drive Monitoring" -- .....	3-14		
3.4.5 Checking I/O signal status -- Menu #4 "I/O Checking" -- .....	3-16		
3.4.6 Reading maintenance information -- Menu #5 "Maintenance Information" -- ....	3-20		
3.4.7 Reading alarm information -- Menu #6 "Alarm Information" -- .....	3-23		
3.4.8 Viewing cause of alarm -- Menu #7 "Alarm Cause" -- .....	3-26		
3.4.9 Data copying -- Menu #8 "Data Copying" -- .....	3-28		
3.4.10 Measuring load factor -- Menu #9 "Load Factor Measurement" --..	3-35		
3.4.11 Changing function codes covered by Quick setup -- Menu #10 "User Setting" -- .....	3-38		
3.4.12 Performing communication debugging -- Menu #11 "Communication Debugging" --	3-39		
3.5 Alarm Mode .....	3-40		
3.6 Other Notes .....	3-42		
3.6.1 Tuning motor parameters.....	3-42		
3.6.2 Password protection .....	3-44		
3.6.3 Connecting to other inverter series.....	3-47		

# Chapter 1 BEFORE USING THE MULTI-FUNCTION KEYPAD

## 1.1 Acceptance Inspection

Unpack the package and check the following:

- (1) The package contains a multi-function keypad and the following attached goods.
  - Attached goods
  - Multi-function keypad fixing screws
  - Instruction manual (this book)
- (2) There have been no problems during transportation. In particular, no parts are damaged or have fallen out of place nor are there any dents on the body.
- (3) The model name "TP-G1-CLS" or "TP-G1-ELS" is printed on the back of the multi-function keypad as shown in Figure 1.1. The language that can be displayed is different in each model name. (Refer to the table below)

Model name	Language that can be displayed
TP-G1-CLS	Chinese, English, Japanese
TP-G1-ELS	English, Japanese, German, French Spanish, Italian

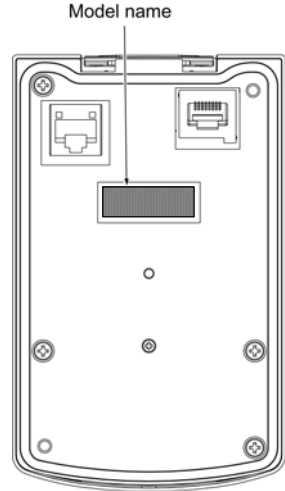

Figure 1.1 Back of Multi-function Keypad TP-G1-CLS / TP-G1-ELS

If you suspect the product is not working properly or if you have any questions about your product, contact your Fuji Electric representative.

## 1.2 Inverters with which the Multi-function Keypad Interfaces

The multi-function keypad interfaces with the following Fuji inverters:

Series	Type of inverter*	Remarks
FRENIC-Lift	FRN□□□LM1S-2□ FRN□□□LM1S-4□ (Each □ has its meaning as shown below, represented by an alphanumeric character.)	No restriction is there for use of this product.

\* Type of inverter

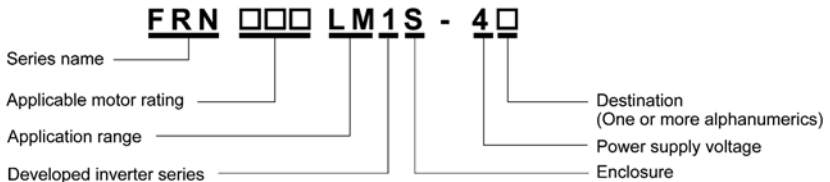

 For the details of the Inverter type identification, refer to the FRENIC-Lift Instruction Manual (INR-SI47-1038-E), Chapter 1, Section 1.1 "Acceptance Inspection."

## Chapter 2 INSTALLATION AND INTERCONNECTION

### 2.1 Accessories and Parts Required for Interconnection

To install the multi-function keypad on the enclosure's panel instead of the inverter, you need the following accessories and parts:

Accessories/Parts	Type or Specifications	Remarks
Remote operation extension cable* <sup>1</sup>	CB-5S, CB-3S, or CB-1S	You have a choice of three lengths: 5 m, 3 m, and 1 m.
Screws (for mounting the multi-function keypad)	M3 x □ * <sup>2</sup>	Provide 2 screws (to be provided by the customer) beforehand.

\*1: Alternatively, you can use an off-the-shelf 10BASE-T/100BASE-TX LAN cable (straight type) that meets the ANSI/TIA/EIA-568A Category 5 standard (maximum length: 20 m).

Recommended LAN cable:

Manufacturer: Sanwa Supply, Co. Ltd.

Model: KB-10T5-01K (for 1 m)

KB-STP-01K (for 1 m) (shielded cable, EMC-compliant)

\*2: Use the screws of the length just right for the panel. (See Figure 2.7.)



## 2.2 Installing the Multi-function Keypad

### 2.2.1 Three ways of installation/use

You can install the multi-function keypad in one of the following three ways:

- Install it directly on the inverter (see Figure 2.1).
- Install it on the front panel of enclosure (see Figure 2.2).
- Use it remotely in your hand (see Figure 2.3).

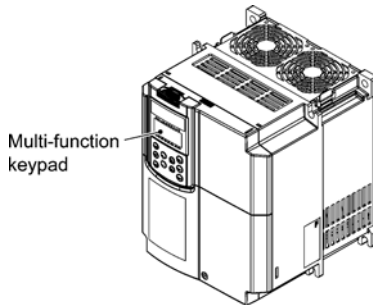

For FRN□□□LM1S-4□

Figure 2.1 Installing Multi-function Keypad Directly on Inverter

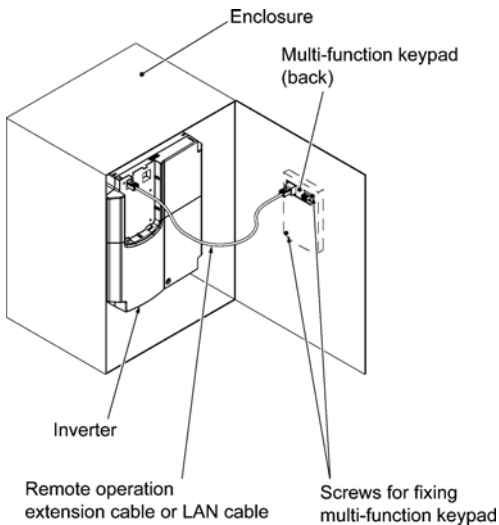

Figure 2.2 Installing Multi-function Keypad on Enclosure

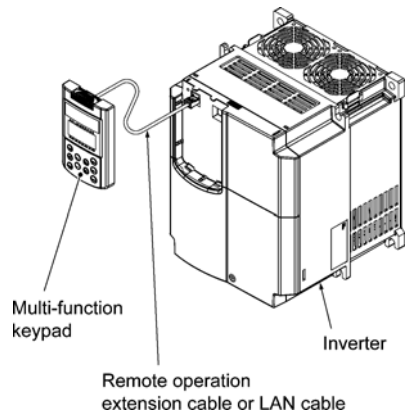

Figure 2.3 Using Multi-function Keypad remotely in Your Hand

## 2.2.2 Installing the multi-function keypad

After completion of interconnection, follow the next steps to install the multi-function keypad in place. Be sure to turn off the power of the inverter beforehand.

### ■ Installing the multi-function keypad directly on the inverter

- ① Remove the blind cover mounted on the inverter.

Pull the blind cover toward you while holding down the hook (as directed by the arrows in Figure 2.4 below).

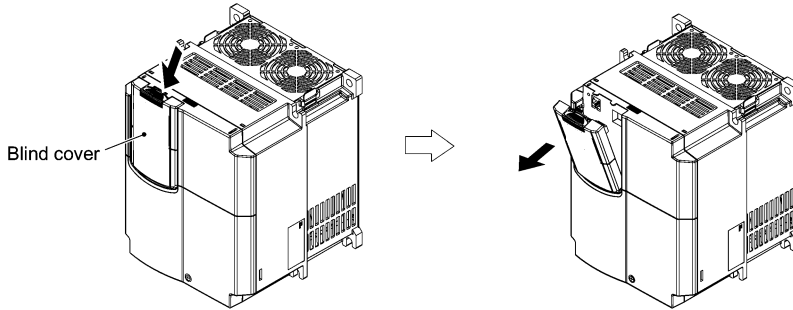

Figure 2.4 Removing the Blind Cover

- ② Mount the multi-function keypad onto the inverter.

Put the multi-function keypad in the original slot while engaging its bottom latches with the holes (as shown below), and push it onto the case of the inverter (arrow ②) while holding it downward (against the terminal block cover) (arrow ①).

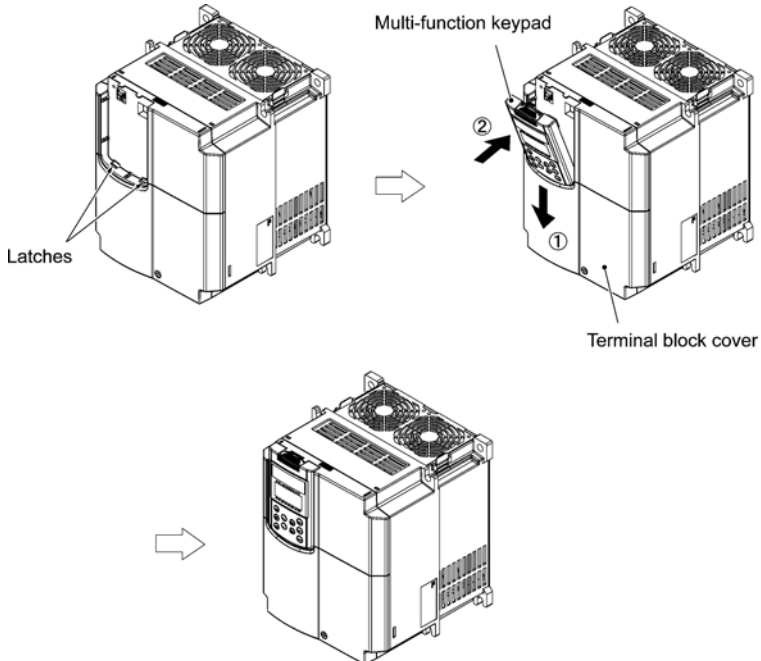



Figure 2.5 Mounting the Multi-function Keypad

**Protection from abnormal vibration: for inverters with capacity of 22 kW or less**

In an environment with large ambient vibrations, the inverter may be exposed to them, causing abnormal vibrations on the multi-function keypad. If this happens, remove the terminal block cover and the front cover, then secure the multi-function keypad to the inverter with the attached screw (Two). After that, reinstall those covers.

 For the procedures for removing the covers, refer to the FRENIC-Lift Instruction Manual (INR-SI47-1038-E), Chapter 2, Section 2.3.1 "Removing and mounting the terminal block (TB) cover and the front cover."

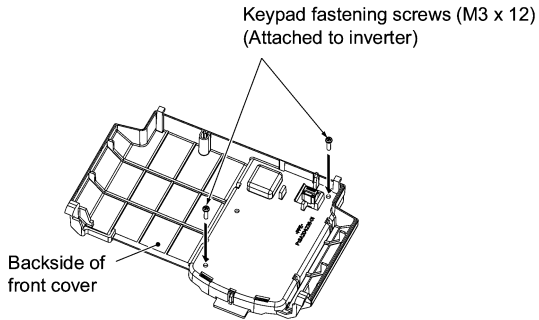
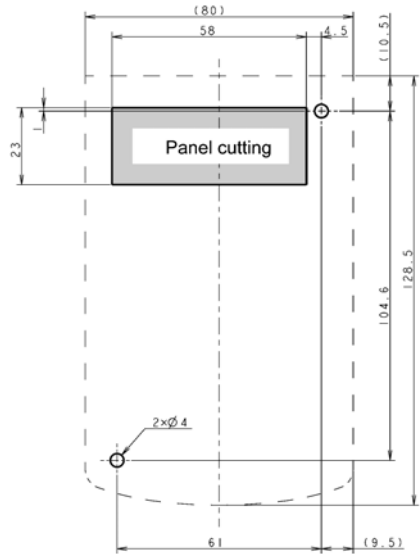
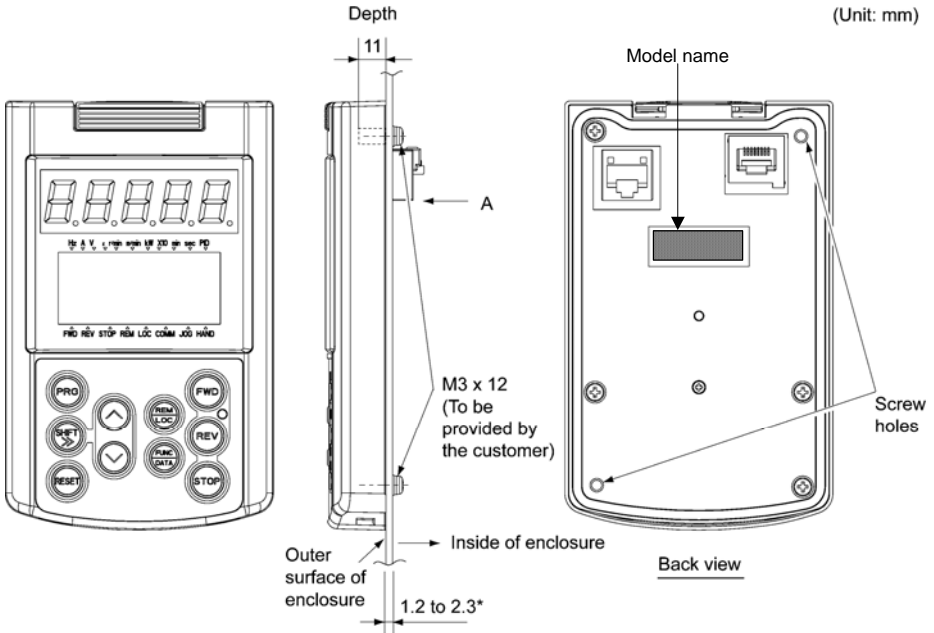

Figure 2.6 Fixing the Multi-function Keypad

■ Installing the multi-function keypad on the enclosure panel

- ① Cut the panel out for a single square area and perforate two screw holes in the panel of the enclosure as shown in Figure 2.7.



Dimensions of holes in enclosure (viewed from A)

Figure 2.7 Dimensions of Square Cut-out and Screw Holes

- ② Mount the multi-function keypad onto the enclosure with 2 screws as shown in Figure 2.8. (Recommended tightening torque: 0.7 N•m)

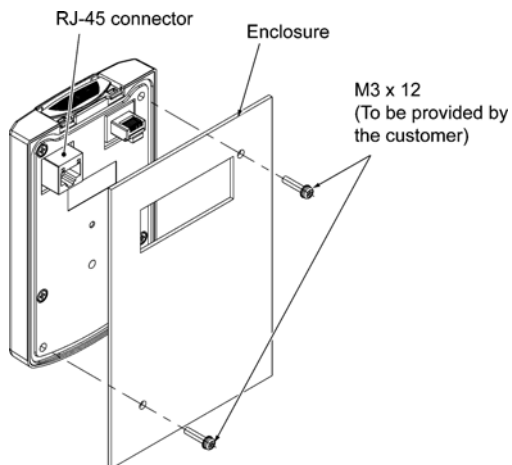

Figure 2.8 Mounting Multi-function Keypad

- ③ Remove the blind cover mounted on the inverter (see Figure 2.4) and, using a remote operation extension cable or a LAN cable, interconnect the multi-function keypad and the inverter (insert one end of the cable into the RS485 port with RJ-45 connector on the multi-function keypad and the other end into that on the inverter) (See Figure 2.9.).

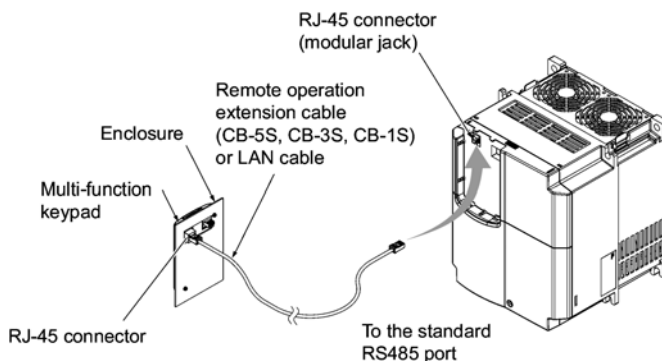

Figure 2.9 Connecting Multi-function Keypad to the Inverter with Remote Operation Extension Cable or an off-the-shelf LAN Cable

#### ■ Using the multi-function keypad in hand

Follow step ③ of "Installing the multi-function keypad on the enclosure panel" above.

# Chapter 3 OPERATION USING THE MULTI-FUNCTION KEYPAD

## 3.1 Components on the Keypad

The keypad allows you to start and stop the motor, view various data including maintenance information and alarm information, set function codes, monitor I/O signal status, copy data, and calculate the load factor.

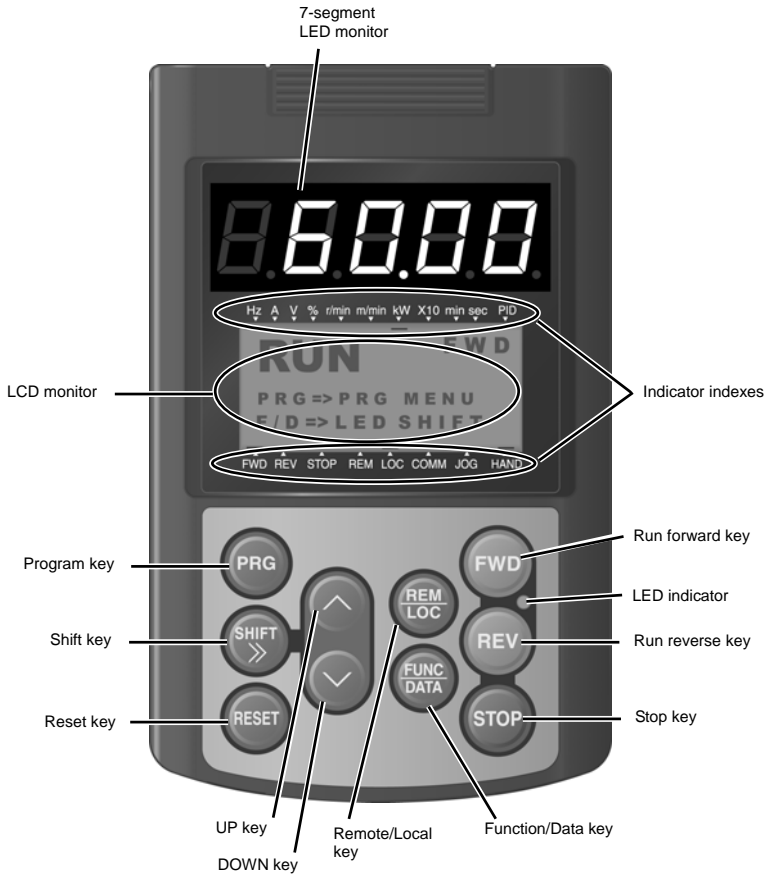





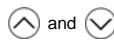







Table 3.1 Overview of Keypad Functions

Item	Monitors and Keys	Functions
7-segment LED monitor and LCD monitor		<p>Five-digit, 7-segment LED monitor which displays the following according to the operation modes:</p> <ul style="list-style-type: none"> <li>■ In Running mode: Running status information (reference speed (final), output current and voltage, etc.)</li> <li>■ In Programming mode: Same as above.</li> <li>■ In Alarm mode: Alarm code, which identifies the cause of an alarm if the protective function is activated.</li> </ul>
		<p>LCD monitor which displays the following according to the operation modes:</p> <ul style="list-style-type: none"> <li>■ In Running mode: Running status information</li> <li>■ In Programming mode: Menus, function codes and their data</li> <li>■ In Alarm mode: Alarm code, which identifies the cause of an alarm if the protective function is activated.</li> </ul>
	Indicator indexes	<p>In Running mode, these indexes show the unit of the number displayed on the 7-segment LED monitor and the running status information on the LCD monitor. For details, see the next page.</p>
Programming keys		Switches the operation modes of the inverter.
		Shifts the cursor to the right when entering a number.
		<p>Pressing this key after removing the cause of an alarm will switch the inverter to Running mode.</p> <p>This key is used to reset settings or screen transition.</p>
		UP and DOWN keys. These keys are used to select the setting items or change the function code data.
		<p>Function/Data key. This key switches the operation as follows:</p> <ul style="list-style-type: none"> <li>■ In Running mode: Pressing this key switches the information to be displayed concerning the status of the inverter (reference speed (final), output current and voltage, etc.).</li> <li>■ In Programming mode: Pressing this key displays the function code and establishes the newly entered data.</li> <li>■ In Alarm mode: Pressing this key displays the details of the problem indicated by the alarm code that has appeared on the LED monitor.</li> </ul>
Operation keys		Starts running the motor in the forward direction. (in local mode only).
		Starts running the motor in the reverse direction. (in local mode only).
		Stops the motor. (in local mode only)
		Holding down this key for more than 1 second toggles between Local and Remote modes.
LED indicator		Lights while a run command is supplied to the inverter.

Items Displayed on LED Indicators

Type	Symbol	Information, Condition, and Status
Unit of number displayed on LED monitor	Hz	Reference speed (final)*1 and reference speed (pre-ramp) *1
	A	Output current
	V	Output voltage
	%	Reference torque, reference torque bias, torque bias balance adjustment value and torque bias gain adjustment value
	r/min	Reference speed (final)*1, reference speed (pre-ramp) *1 and motor speed
	m/min	Reference speed (final)*1, reference speed (pre-ramp) *1 and elevator speed
	kW	Input power
	X10	Data exceeding 99,999
	min	Not applicable
	sec	Not applicable
	PID	Torque bias balance adjustment and torque bias gain adjustment.
Running status	FWD	Running in forward direction
	REV	Running in reverse direction
	STOP	Stopped state (No output or detected speed "0")
Run command source	REM	Remote mode
	LOC	Local mode
	COMM	Via communication (RS485-1, CAN)
	JOG	Jogging mode
	HAND	Via keypad (Lights also in local mode)

\*1 Function code C21 provides a choice of units--r/min, m/min, and Hz.

The speed-frequency conversion formulas are given below.

$$[r/min] = 120 \times \frac{[Hz]}{P01} \quad [m/min] = \frac{L31}{F03} \times 120 \times \frac{[Hz]}{P01}$$

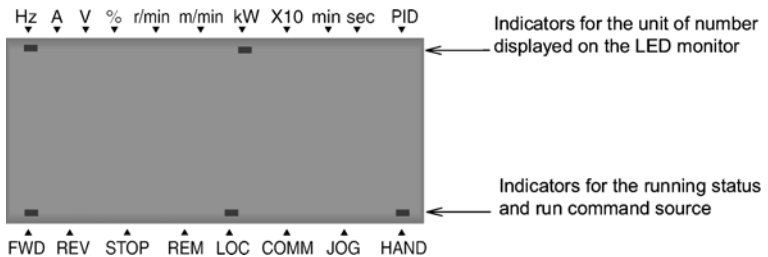



### 3.2 Overview of Operation Modes

FRENIC-Lift features the following three operation modes:

- **Running mode:** This mode allows you to enter run/stop commands in regular operation. You can also monitor the running status in real time.
- **Programming mode:** This mode allows you to set function code data and check a variety of information relating to the inverter status and maintenance.
- **Alarm mode:** If an alarm condition arises, the inverter automatically enters the Alarm mode. In this mode, you can view the corresponding alarm code\* and its related information on the LED and LCD monitors.

 Alarm code represents the type of alarms that have been triggered by the protection function. For details, refer to the FRENIC-Lift Instruction Manual (INR-SI47-1038-E), Chapter 8, Section 8.5 "Protection Features."

Figure 3.1 shows the status transition of the inverter between these three operation modes.

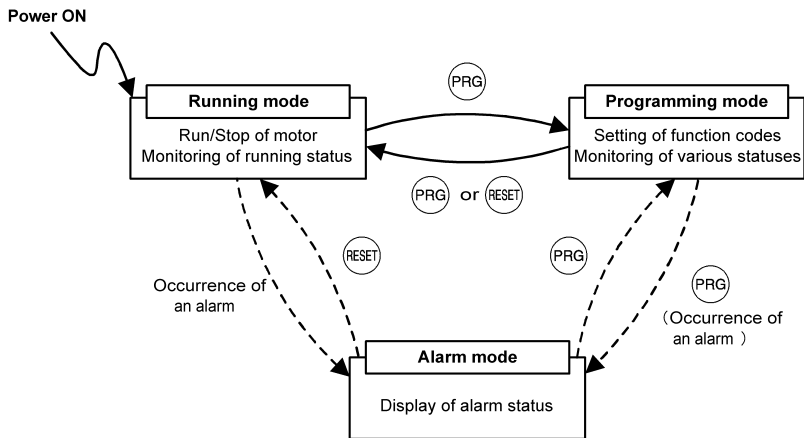

Figure 3.1 Status Transition between Operation Modes

### 3.3 Running Mode

When the inverter is turned on, it automatically enters Running mode. In Running mode, you can:

- [ 1 ] Run or stop the motor (in local mode only),
- [ 2 ] Set the reference speed (pre-ramp) (in local mode only), and
- [ 3 ] Monitor the running status (e.g., reference speed (final), output current, etc.)

#### 3.3.1 Running/stopping the motor

In local mode, pressing the **FWD** or **REV** key starts running the motor in the forward or reverse direction, respectively. Pressing the **STOP** key decelerates the motor to stop. This keypad operation is enabled only in Running and Programming modes.

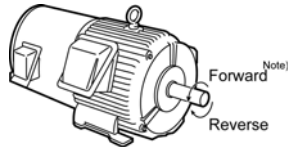

Figure 3.2 Rotational Direction of Motor

Note) The rotational direction of IEC-compliant motor is opposite to the one shown here.

#### ■ Displaying the running status on the LCD monitor

(1) When function code E45 data (LCD monitor item selection) is set to "0"

The LCD monitor displays the running status, the rotational direction, and the operation guide.

(The lower indicators show the running status and run command source. For the upper ones, see Section 3.3.3.)

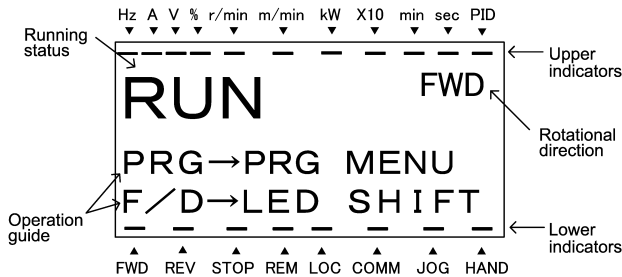

Figure 3.3 Display of Running Status

The running status and the rotational direction are displayed as listed in Table 3.2.

Table 3.2 Running Status and Rotational Direction

Status/Direction	Display	Meaning
Running status	RUN	A run command is present or the inverter is driving the motor.
	STOP	A run command is not present and the inverter is stopped.
Rotational direction	FWD	Forward rotation being commanded.
	REV	Reverse rotation being commanded.
	Blank	The inverter is stopped (output shut down) or running at zero speed.

(2) When function code E45 data (LCD monitor item selection) is set to "1"

The LCD monitor displays the reference speed (final), output current, and reference torque in a bar chart. (The lower indicators show the running status and run command source. For the upper ones, see Section 3.3.3.)

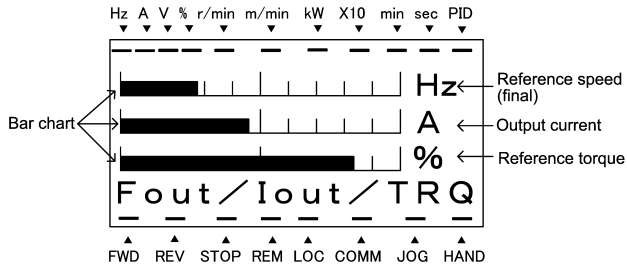

The full scale (maximum value) for each item is as follows:  
 Reference speed (final): Maximum speed  
 Output current: 200% of inverter rated current  
 Reference torque: 200% of motor rated torque

Figure 3.4 Bar Chart

■ Switching between remote and local modes

The inverter can be operated either in remote or local mode. In remote mode, which applies to normal operation, the inverter is driven under the control of the data settings stored in the inverter, whereas in local mode, which applies to maintenance operation, it is separated from the control system and is driven manually under the control of the keypad.

- Remote mode: The run and speed command sources are determined by source switching signals including function codes and communications link operation signal. The keypad cannot be used as a command source.
- Local mode: The keypad is enabled as a run and speed command source, regardless of the settings specified by function codes. The keypad takes precedence over a communications link operation signal or other command sources.

Holding down the  key for at least one second switches between remote and local modes. Switching to remote mode turns on the lower indicator above the REM index, and switching to local mode, above the LOC index.

When the mode is switched from remote to local, the reference speed (pre-ramp) specified in remote mode is automatically inherited. Further, if the run command is ON at the time of the switching, the inverter automatically turns on such a run command in the keypad that carries over the rotational direction.

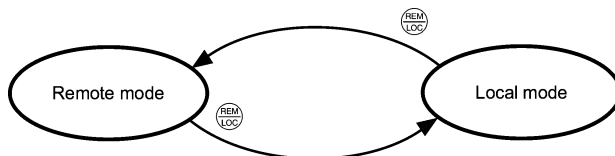

Figure 3.5 Transition between Remote and Local Modes

**⚠ WARNING**

In local mode, operation (such as issuing run or speed command) on the remote side is disabled. Do not switch from remote to local mode while the motor is loaded.

**Accidents or injuries may result.**

### 3.3.2 Setting the reference speed (pre-ramp)

You can set the reference speed (pre-ramp) in frequency (Hz) with the  $\triangleleft$  /  $\triangleright$  keys on the keypad in local mode.

#### Using $\triangleleft$ / $\triangleright$ keys in local mode

- (1) Switch the keypad to Running mode. This is because in Programming or Alarm mode, the  $\triangleleft$  /  $\triangleright$  keys are disabled to set the reference speed (pre-ramp).
- (2) Press the  $\triangleleft$  /  $\triangleright$  keys to display the reference speed (pre-ramp) on the LCD monitor with the lowermost digit blinking.

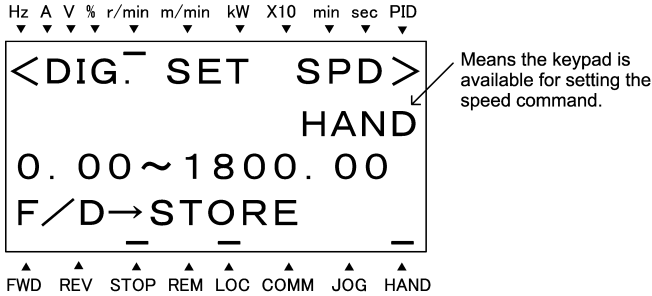

Figure 3.6 Setting the Speed Command in Local Mode

- (3) The newly specified speed is not automatically saved in the inverter, so specify the speed again if necessary when you restart the inverter.



- When the speed monitor is selected (E43 = 0), the reference speed (pre-ramp) can be specified with the  $\triangleleft$  /  $\triangleright$  keys.
- E48 specifies the speed-monitoring formats (unit). For details about the LED monitor, refer to Section 3.3.3.
- When you start accessing the reference speed (pre-ramp) with the  $\triangleleft$  /  $\triangleright$  keys, the lowest digit on the display will blink and start changing. As you are holding down the key, blinking will gradually move to the upper digit places and the upper digits will be changeable.
- Pressing the  $\text{E48}$  key moves the changeable digit place (blinking) and thus allows you to change upper digits easily.

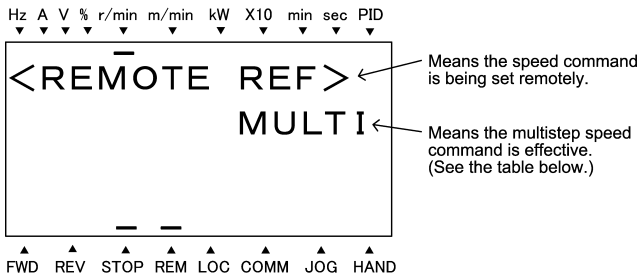

Table 3.3 Available Speed Command Sources

Symbol	Command source	Symbol	Command source
HAND	Keypad	MULTI	Multistep speed command
ANALOGNR	Analog speed command (Not reversible)	ANALOG_R	Analog speed command (Reversible)
RS485-1	Via RS485 communications link	LOADER	Via FRENIC Loader
JOG	Jogging operation	CAN	Via CAN communications link

### 3.3.3 Monitoring the running status on the LED monitor

The ten items listed below can be monitored on the 7-segment LED monitor. Immediately after the power is turned ON, the monitor item specified by function code E43 is displayed.

Pressing the  key in Running mode switches between monitor items in the sequence shown in Table 3.4.

Table 3.4 Monitor Items

Monitor page #	Monitor Items	Example	Unit	Meaning of Displayed Value	Function code E43
0	Speed monitor	Function code E48 specifies what to be displayed.			0
	Reference speed (final)	100	r/min*1 m/min Hz	Reference speed (final) commanded to the Automatic Speed Regulator (ASR)	(E48 = 0)
	Reference speed (pre-ramp)	100	r/min*1 m/min Hz		(E48 = 2)
	Motor speed	1500	r/min	Motor rotation speed	(E48 = 3)
Elevator speed	111.1	m/min	Elevator speed	(E48 = 5)	
8	Output current	12.34	A	Output of the inverter in current in rms	3
9	Input power	10.25	kW	Input power to the inverter	9
10	Calculated torque	200	%	Torque in % based on the motor rated torque being at 100%*2	8
11	Output voltage	256.0	V	Output of the inverter in voltage in rms	4
19	Reference torque	200	%	Torque in % based on the motor rated torque being at 100%	18
20	Torque bias balance adjustment value BTBB	64.0	%	Used to adjust the analog torque bias balance	19
21	Torque bias gain adjustment value BTBG	400.0	%	Used to adjust the analog torque bias gain	20

\*1 Function code C21 provides a choice of units--r/min, m/min, and Hz.

\*2 In vector control with PG, this item shows the reference torque.

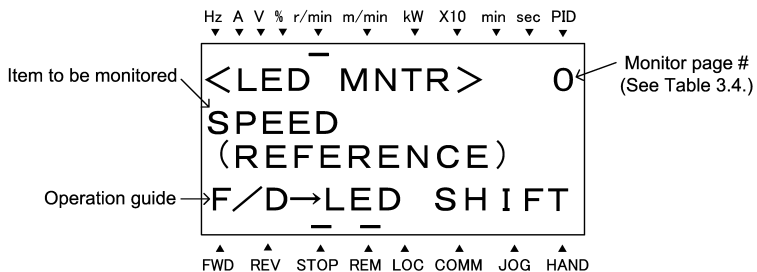

Figure 3.7 Display Sample of LED Monitor Item

### 3.4 Programming Mode

Programming mode allows you to set and check function code data and monitor maintenance information and input/output (I/O) signal status. The functions can be easily selected with a menu-driven system. Table 3.5 lists menus available in Programming mode.

Table 3.5 Menus Available in Programming Mode

Menu #	Menu	Main functions	Refer to:
0	"Quick Setup"	Displays only basic function codes pre-selected.	3.4.2
1	"Data Setting"	Allows you to view and change the setting of the function code you select. (Note)	3.4.1
2	"Data Checking"	Allows you to view and change a function code and its setting (data) on the same screen. Also this allows you to check the function codes that have been changed from their factory defaults.	3.4.3
3	"Drive Monitoring"	Displays the running information required for maintenance or test running.	3.4.4
4	"I/O Checking"	Displays external interface information.	3.4.5
5	"Maintenance Information"	Displays maintenance information including cumulative run time.	3.4.6
6	"Alarm Information"	Displays four latest alarm codes. Also this allows you to view the information on the running status at the time the alarm occurred.	3.4.7
7	"Alarm Cause"	Displays the cause of the alarm.	3.4.8
8	"Data Copying"	Allows you to read or write function code data, as well as verifying it.	3.4.9
9	"Load Factor Measurement"	Allows you to measure the maximum output current, average output current, and average braking power.	3.4.10
10	"User Setting"	Allows you to add or delete function codes covered by Quick Setup.	3.4.11
11	"Communication Debugging"	Allows you to confirm the data of function codes for communication (S, M, W, X, and Z codes).	3.4.12

Figure 3.8 shows the transitions between menus in Programming mode.

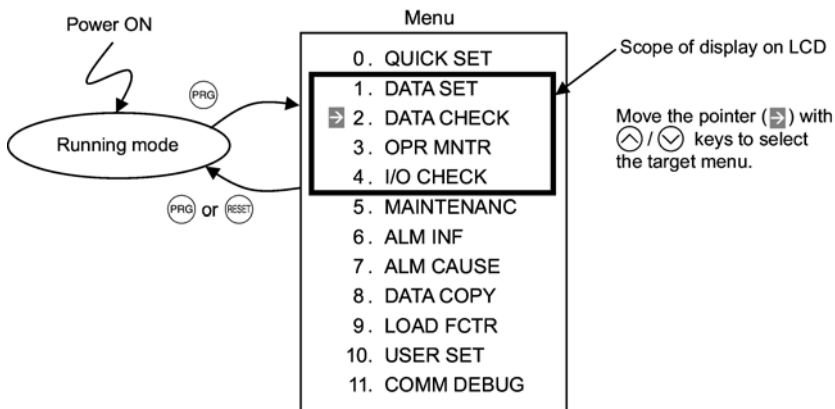

Figure 3.8 Menu Transition in Programming Mode

If no key is pressed for approx. 5 minutes, the inverter automatically goes back to Running mode and turns the backlight OFF.

### 3.4.1 Setting function codes -- Menu #1 "Data Setting" --





Menu #1 "Data Setting" in Programming mode allows you to set function codes for making the inverter functions match your needs.

Table 3.6 lists the function codes available on the FRENIC-Lift.

Table 3.6 Function Codes Available on FRENIC-Lift

Function Code Group	Function	Description
F code (Fundamental functions)	Fundamental functions	Functions concerning basic motor running
E code (Extension terminal functions)	Terminal functions	Functions concerning the assignment to control circuit terminals Functions concerning the display of the LED monitor
C code (Control functions)	Control functions	Functions associated with speed settings
P code (Motor parameters)	Motor parameters	Functions for setting up characteristics parameters (such as capacity) of the motor
H code (High performance functions)	High-level functions	Highly added-value functions; Functions for sophisticated control
y code (Link functions)	Link functions	Functions for controlling communication
L code (Lift functions)	Lift functions	Functions for controlling elevators (lifts)

#### ■ Function codes requiring simultaneous keying

To modify the data for function code F00 (Data Protection), H03 (Data Initialization), H97 (Clear Alarm Data), or H99 (Password Protection), simultaneous keying is needed, involving the  +  keys or the  +  keys.

#### ■ Changing, validating, and saving function code data when the invert is running

Some function codes can be changed while the inverter is running, whereas others cannot. Further, depending on the function code, modifications may or may not become effective immediately. For details, refer to the "Change when running" column in Section 5.1 "Function Code Tables" in the FRENIC-Lift Instruction Manual (INR-SI47-1038-E).

 For details of function codes, refer to the FRENIC-Lift Reference Manual (INR-SI47-1068-E).

Figure 3.9 shows the LCD screen transition for "1. DATA SET."

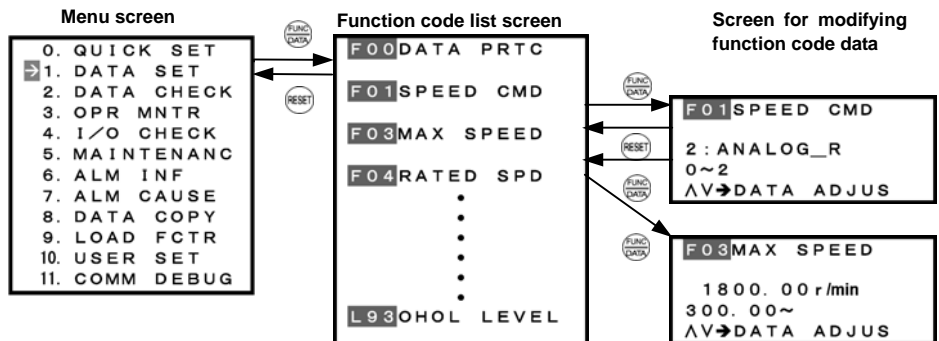

Figure 3.9 Screen Transition to "1. DATA SET"

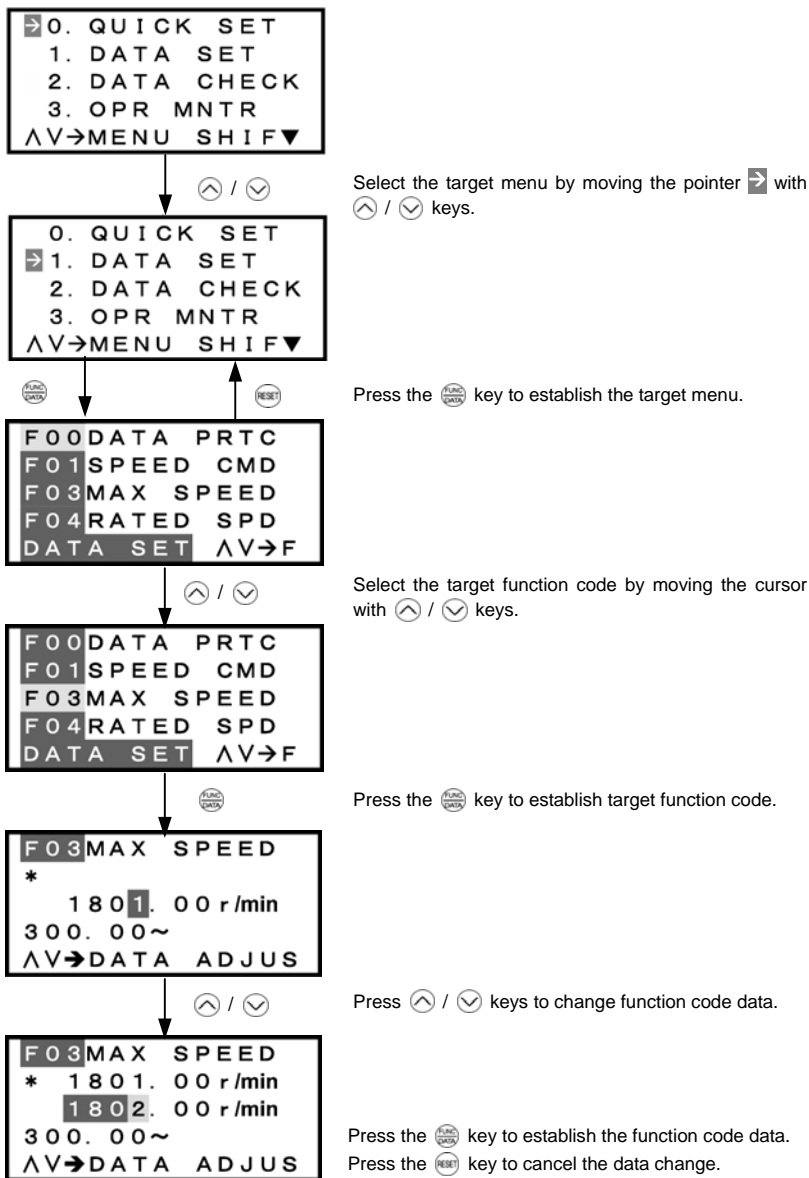

Figure 3.11 Changing Function Code Data



## Basic key operation

This section gives a description of the basic key operation, following the example of the function code data changing procedure shown in Figure 3.10.

This example changes function code F03 data (maximum speed) from 1801.00 to 1802.00 r/min.

- (1) When the inverter is powered on, it automatically enters Running mode. In Running mode, press the **PROG** key to enter Programming mode. The menu for function selection will appear.
- (2) Use the **▲** / **▼** keys to move the pointer **▶** to "1. DATA SET" and then press the **ENTER** key. A list of function codes appears.
- (3) Use the **▲** / **▼** keys to select the target function code group (F03 in this example) and press the **ENTER** key, which displays the screen for changing the target function code data.
- (4) Use the **▲** / **▼** keys to change the function code data. Pressing the **ENTER** key causes the blinking digit place to shift (cursor shifting) (The blinking digit can be changed).
- (5) Press the **ENTER** key to establish the function code data.  
The data will be saved in the memory inside the inverter. The display will return to the function code list, then move to the next function code (F04 in this example).  
Pressing the **RESET** key preceding the **ENTER** key cancels the change made to that function code data. The data reverts to the previous value, the screen returns to the function code list, and the function code (F03) reappears.
- (6) Press the **RESET** key to return to the menu from the function code list.

Screen

Function code      Function code name

Operation guide: The function of each key is displayed by automatic scrolling of this line.

Function code # and name  
\*: Function code that has been changed from factory default  
Data  
Allowable range  
Operation guide

Data before change  
Data after change

Figure 3.10 Screen for Changing Function Code Data



- Additional note on function code being selected

The function code being selected blinks, indicating the movement of the cursor (F03 blinks in this example).

### 3.4.2 Setting up function codes quickly -- Menu #0 "Quick Setup" --

Menu #0 "Quick Setup" in Programming mode allows you to quickly set up a fundamental set of function codes that you specify beforehand. Whereas at shipment from factory, no function code is registered for Quick Setup, you can add or delete some function codes using Menu #10 "User Setting." The set of function codes covered by Quick Setup is held in the inverter (not the keypad). Therefore, if you mount your keypad onto another inverter, the set of function codes held in the new inverter is subject to Quick Setup. If necessary, you may copy the set of function codes subject to Quick Setup using the copy function (Menu #8 "Data Copying").

If you perform data initializing (function code H03), the set of function codes subject to Quick Setup will be reset to the factory default.

The LCD screen transition from Menu #0 is the same as with Menu #1 "Data Setting."

#### Basic key operation

Same as the basic key operation for Menu #1 "Data Setting."

### 3.4.3 Checking changed function codes -- Menu #2 "Data Checking" --

Menu #2 "Data Checking" in Programming mode allows you to check function codes (together with their data) that have been changed. The function codes changed from the factory default are marked with \*. By selecting a particular function code and pressing the  key, you can view or change its data.

The LCD screen transition from Menu #2 is the same as with Menu #1 "Data Setting," except for the different screen listing function codes as shown below.

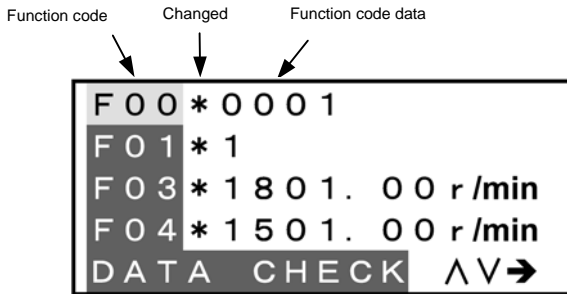

Figure 3.12 Function Code List Screen

#### Basic key operation

Same as the basic key operation for Menu #1 "Data Setting."

### 3.4.4 Monitoring the running status -- Menu #3 "Drive Monitoring" --

Menu #3 "Drive Monitoring" in Programming mode allows you to check the running status during maintenance and test running. The display items for "Drive Monitoring" are listed in Table 3.7.

Table 3.7 Drive Monitoring Display Items

Item	Symbol	Description
Reference speed (final)	Fot1	Reference speed (final) commanded to the Automatic Speed Regulator (ASR) (Hz)
Output frequency	Fot2	Frequency being output (Hz)
Output current	Iout	Output current value (A)
Output voltage	Vout	Output voltage value (V)
Calculated torque	TRQ	Torque (%) based on the motor rated torque being at 100%*1
Reference speed (pre-ramp)	Fref	Reference speed (pre-ramp) currently specified (Hz)
Rotation direction	FWD	Running forward
	REV	Running reverse
	Blank	Stopped
Running status	IL	Current limiting
	LU	Undervoltage detected
	TL	Torque limiting
Motor speed	SYN	Detected speed (r/min)
Elevator speed	LIN	Detected speed (m/min)
Reference torque bias	TRQB	Value (%) based on the motor rated torque being at 100%
Reference torque	TRQC	Value (%) based on the motor rated torque being at 100%
Reference torque current	TRQI	Value (%) based on the motor rated current being at 100%
Electronic thermal for motor	OLM	Value (%) based on the electronic thermal overload protection level being at 100%*2

\*1 In vector control with PG, this item shows the reference torque.

\*2 It is not supported in a certain ROM version of the inverter. It displays "---" for symbols not supported. When ROM version of a multi-function keypad is 8800, it doesn't display "OLM".

**Note:** FRENIC-Lift supports only symbols listed in the above table. It displays "---" for symbols not supported.

#### Basic key operation









- (1) When the inverter is powered on, it automatically enters Running mode. In Running mode, press the  key to enter Programming mode. The menu for function selection will appear.
- (2) Use the  /  keys to move the pointer  to "3. OPR MNTR."
- (3) Press the  key to display the monitor screen (one out of a total of 6 pages).
- (4) Use the  /  keys to select the target item page and confirm the running status information for that item.
- (5) Press the  key to go back to the menu.

Figure 3.13 shows the LCD screen transition for "3. OPR MNTR."

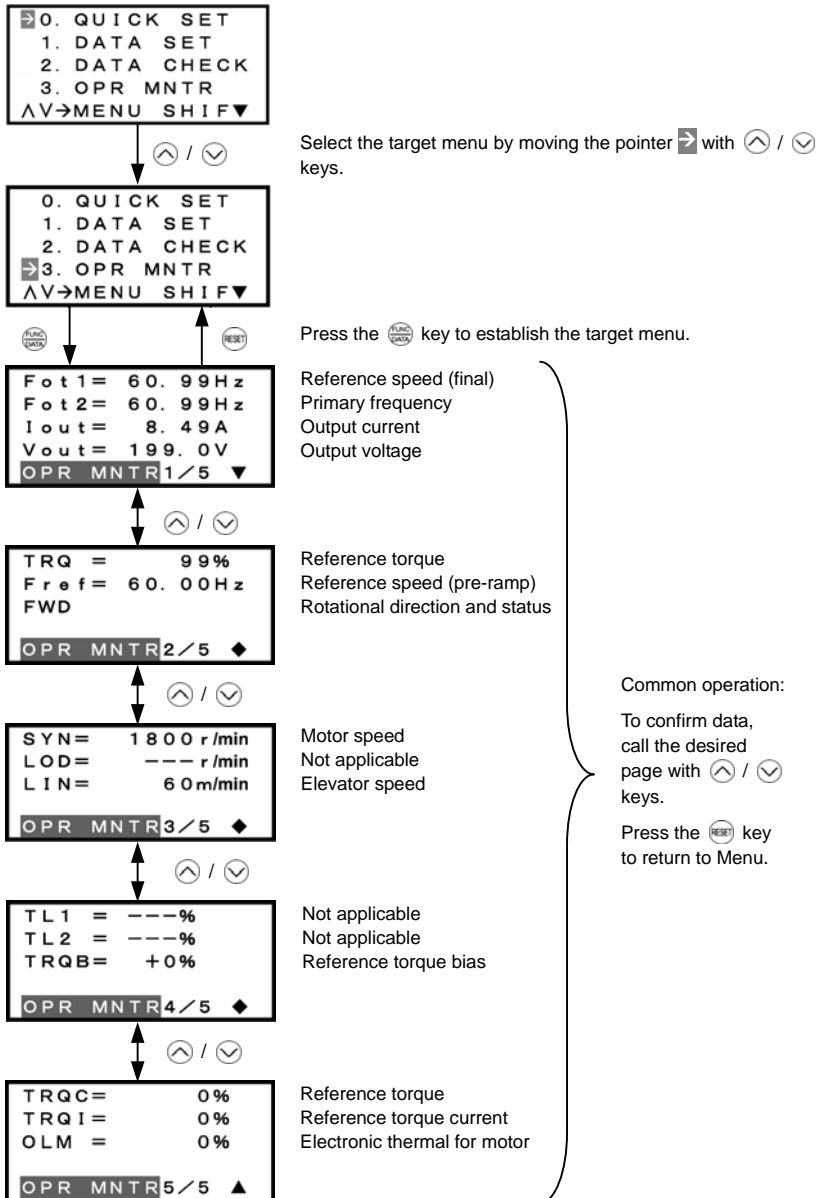

Figure 3.13 Screen Transition for "3. OPR MNTR"

### 3.4.5 Checking I/O signal status -- Menu #4 "I/O Checking" --

Menu #4 "I/O Checking" in Programming mode allows you to check the digital and analog input/output signals coming in/out of the inverter. This menu is used to check the running status during maintenance or test run.

Table 3.8 lists check items available.

Table 3.8 I/O Check Items

Item	Symbol	Description
Input status at terminal	FWD, REV, X1 to X8 and EN	Input signal information at the control circuit terminals (Highlighted when short-circuited; normal when open)
Input status at terminal via communications link	FWD, REV, X1 –to X8, XF, XR and RST	Input signal information via communications link (Highlighted when 1; normal when 0)
Output status at terminal	Y1 to Y5 and 30A/B/C	Output signal information (Highlighted when ON; normal when OFF)
I/O status (hexadecimal)	DI	Input signal information at the control circuit terminals (hexadecimal)
	DO	Output signal information (hexadecimal)
	LNK	Input signal information via communications link (hexadecimal)
Analog input signals	12	Input voltage at terminal [12]
	C1	Input current at terminal [C1]
	V2	Input voltage at terminal [V2]
Phase angle	$\theta_e$	Output electrical angle
	$\theta_{re}$	Magnet pole position detection angle (only when the PP option is mounted)
	$\theta_m$	Detected mechanical angle (only when the PS option is mounted)
	PPb	Magnet pole position detection signal in binary (only when the PP option is mounted)
Encoder pulse frequency	P2	Encoder pulse frequency for A-phase and B-phase
	Z2	Encoder pulse frequency for Z-phase

**Note:** FRENIC-Lift supports only symbols listed in the above table. It displays "----" for symbols not supported.

#### **Basic key operation**









- (1) When the inverter is powered on, it automatically enters Running mode. In Running mode, press the  key to enter Programming mode. The menu for function selection will appear.
- (2) Use  /  keys to move the pointer  to "4. I/O CHECK."
- (3) Press the  key to display the I/O checking screen (one out of a total of 9 pages).
- (4) Use  /  keys to select the target item page and confirm the I/O check data for that item.
- (5) Press the  key to go back to the menu.

Figure 3.14 shows the LCD screen transition for "4. I/O CHECK."

```

0. QUICK SET
1. DATA SET
2. DATA CHECK
3. OPR MNTR
^V→MENU SHIF▼

```

Select the target menu by moving the pointer **→** with **^** / **▼** keys.

```

1. DATA SET
2. DATA CHECK
3. OPR MNTR
→4. I/O CHECK
^V→MENU SHIF◆

```

Press the **FUNC DATA** key to establish the target menu.

**Input status at terminal**

Highlighted when short-circuited; normal when open

```

TRM X2 X6 --
FWD X3 X7 --
REV X4 X8 --
X1 X5 EN
I/O CHECK1/8▼

```

**Input status at terminal via communications link**

Highlighted when 1; normal when 0

```

LNK X2 X6 XF
FWD X3 X7 XR
REV X4 X8 RST
X1 X5 --
I/O CHECK2/8◆

```

**Output status at terminal**

Highlighted when ON; normal when OFF

```

Y1 Y5
Y2 30ABC
Y3
Y4
I/O CHECK3/8◆

```

**I/O status (hexadecimal)**

Input signal information at the control circuit terminals  
Output signal information  
Input signal information via communications link

```

Di = 0000H
Do = 0000H
LNK = 0000H
I/O CHECK4/8◆

```

**Analog input status**

Input voltage at terminal [I2]  
Input current at terminal [C1]  
Input voltage at terminal [V2]

```

I2 = +0.0V
C1 = 0.0mA
V2 = +0.0V
I/O CHECK5/8◆

```

Not applicable  
Not applicable

```

Di-o = ---H
Do-o = ---H
I/O CHECK6/8◆

```

Common operation:

To confirm data, call the desired page with **^** / **▼** keys.

Press the **RESET** key to return to Menu.

Figure 3.14 Screen Transition for "4. I/O CHECK"

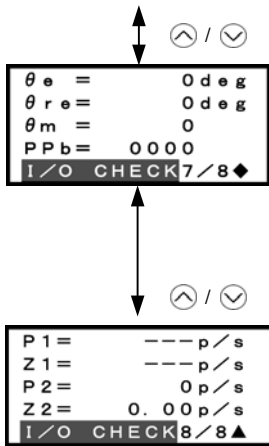

### Phase angle

Output electrical angle  
 Magnet pole position detection angle  
 (only when the PP option is mounted)  
 Detected mechanical angle  
 (only when the PS option is mounted)  
 Magnet pole position detection signal  
 in binary (only when the PP option is  
 mounted)

### Encoder pulse frequency

Not applicable  
 Not applicable  
 Encoder pulse frequency for A- and  
 B-phase  
 Encoder pulse frequency for Z-phase

Common  
 operation:  
 To confirm  
 data, call the  
 desired page  
 with ^ /  
 ▽ keys.  
 Press the  
 RESET key to  
 return to  
 Menu.

Figure 3.14 Screen Transition for "4. I/O CHECK" (continued)

### ■ I/O status (hexadecimal)

Each I/O terminal is assigned to one of the 16 binary bits (bit 0 through bit 15). The bit to which no I/O terminal is assigned is considered to have a value of "0." The I/O status is thus collectively expressed as a hexadecimal number (0 through F).

In the FRENIC-Lift series, digital input terminals [FWD] and [REV] are assigned to bits 0 and 1, [X1] through [X8] to bits 2 through 9, and EN terminal to bit 10, respectively. Each bit assumes a value of "1" when the corresponding signal is ON and a value of "0" when it is OFF<sup>(Note)</sup>. For example, when signals [FWD] and [X1] are ON while all other signals are OFF, the status is expressed as "0005H."

Digital output terminals [Y1] through [Y4] are assigned to bits 0 through 3. Each is given a value of "1" when it is short-circuited to [CMY], or a value of "0" when its circuit to [CMY] is open. The status of relay output terminal [Y5A/C] is assigned to bit 4, which assumes a value of "1" when the contact between [Y5A] and [Y5C] is closed. The status of relay output terminal [30A/B/C] is assigned to bit 8, which assumes a value of "1" when the contact between [30A] and [30C] is closed or "0" when the contact between [30B] and [30C] is closed. For example, when terminal [Y1] is ON, terminals [Y2] to [Y4] are OFF, the contact between [Y5A] and [Y5C] is opened, and the link between 30A and 30C is closed, then the status is expressed as "0101H."

Table 3.9 Hexadecimal Notation

Data Displayed		Highest digit								Lowest digit							
		Bit	15	14	13	12	11	10	9	8	7	6	5	4	3	2	1
Input signal		(RST) <sup>*1</sup>	(XR) <sup>*1</sup>	(XF) <sup>*1</sup>	-	-	(EN) <sup>*2</sup>	X8	X7	X6	X5	X4	X3	X2	X1	REV	FWD
Output signal		-	-	-	-	-	-	30A/B/C	-	-	-	Y5A/C	Y4	Y3	Y2	Y1	
Example (Input)	Binary	0	0	0	0	0	0	0	0	0	0	0	0	0	1	0	1
	Hex	0005 <sub>H</sub>															

-: Unassigned

\*1 (XF), (XR), (RST) are for communication. Refer to the section given below.

\*2 (EN) is for monitoring and cannot be used for input entered via a communications link.

### ■ Input status at terminal via communication link

Input commands sent via RS485 or CAN communications can be displayed in two ways: "Input status at terminal via communication link" or "I/O status (hexadecimal)." The content to be displayed is basically the same as that for the input signal information at control circuit terminals (hexadecimal) of display; however, (XF), (XR), and (RST) are added as inputs. Note it is a display of normal logic (Active-ON) (using the original signals that are not inverted).

 Refer to the RS485 Communication User's Manual for details on input commands sent through RS485 communications. For details on CAN communication, refer to the CAN Communication User's Manual.

### ■ Magnet pole position detection signals in binary

When the synchronous motor drive option "OPC-LM1-PP" is used, the status of the magnet pole position detection signal input to the option is displayed in binary, "1" for ON and "0" for OFF. F3, F2 (W), F1 (V) and F0 (U) are assigned from the left in this order. When the input signal is ON, it displays "1," and when the input signal is OFF, it displays "0."

### ■ Encoder pulse frequency

When you set 1 to L01, the frequency of the encoder feedback pulse (Z phase) is displayed. When ROM version of a multi-function keypad is 8800, the decimal point is not displayed.



### 3.4.6 Reading maintenance information -- Menu #5 "Maintenance Information" --

Menu #5 "Maintenance Information" in Programming mode allows you to view information necessary for performing maintenance on the inverter.

Table 3.10 lists the maintenance information display items.

Table 3.10 Display Items for Maintenance

Item	Symbol	Description
Cumulative operation time	TIME	Shows the cumulative operation time during which the inverter was powered ON. When the total time exceeds 65,535 hours, the counter will be reset to 0 and the count will start again.
DC link circuit voltage	EDC	Shows the DC link circuit voltage of the inverter's main circuit.
Max. inverter internal air temperature	TMPI	Shows the maximum temperature inside the inverter every hour.
Max. heat sink temperature	TMPF	Shows the maximum temperature of the heat sink every hour.
Max. effective current value	Imax	Shows the maximum current in RMS every hour.
Internal capacitance of the DC bus capacitor	CAP	Shows the current capacitance of the DC bus capacitor as % of the capacitance at factory shipment. Refer to the FRENIC-Lift Instruction Manual (INR-SI47-1038-E), Chapter 7 "MAINTENANCE AND INSPECTION" for details.
Cumulative operation time of motor	MTIM	Shows the cumulative run time of the motor. When the total time exceeds 65,535 hours, the counter will be reset to 0 and the count will start again.
Cumulative run time of capacitors on printed circuit board	TCAP	Shows the product of the cumulative time of voltage being applied to the electrolytic capacitor on the printed circuit board and a coefficient determined by the environmental condition. When the total time exceeds 65,535 hours, the counting will stop. As a guide, 61,000 hours is considered as life.
Cumulative run time of cooling fan	TFAN	Shows the cumulative run time of the cooling fan. When the total time exceeds 65,535 hours, the counting will stop. As a guide, 61,000 hours is considered as life (This number varies with the capacity of the inverter.)
Number of startups	NST	Shows the total number of startups of the motor (number of times when the run command for the inverter was turned ON). When the number of times exceeds 65,535 times, the counter will be reset to 0 and the count will start again.
Cumulative power consumption	Wh	Shows the cumulative power consumption of the inverter. Upon exceeding 1,000,000 kWh, the count goes back to 0.
Number of RS485 communications errors	NRR1	Shows the cumulative number of RS485 communications (standard) errors since first power ON.
Contents of RS485 communications error <sup>*1</sup>		Shows the latest error that has occurred with RS485 communications (standard) in a code.
ROM version of the inverter	MAIN	Shows the ROM version of the inverter in 4 digits.
ROM version of the keypad	KP	Shows the ROM version of the keypad in 4 digits.
ROM version of the option	OP1	Shows the ROM version of the option in 4 digits.
Option name	OPC	Shows the name of the option currently connected.

\*1 For details of errors, refer to the RS485 Communication User's Manual.

**Note:** FRENIC-Lift supports only symbols listed in the above table. It displays "---" for symbols not supported.

### **Basic key operation**









- (1) When the inverter is powered on, it automatically enters Running mode. In Running mode, press the  key to enter Programming mode. The menu for function selection will appear.
- (2) Use the  /  keys to move the pointer  to "5. MAINTENANC."
- (3) Press the  key to display the maintenance screen (one out of a total of 7 pages).
- (4) Use the  /  keys to select the target item page and confirm the maintenance data for that item.
- (5) Press the  key to go back to the menu.

Figure 3.15 shows the LCD screen transition for "5. MAINTENANC."

```

0. QUICK SET
 1. DATA SET
 2. DATA CHECK
 3. OPR MNTR
 4. I/O CHECK
 5. MAINTENANC
  ^V→MENU SHIF▼
  
```

Select the target menu by moving the pointer → with ▲ / ▼ keys.

```

2. DATA CHECK
 3. OPR MNTR
 4. I/O CHECK
 5. MAINTENANC
  ^V→MENU SHIF◆
  
```

Press the  key to establish the target menu.

```

TIME= 14 h
EDC = 493 V
TMP I = 38 °C
TMP F = 78 °C
MAINTENANC1/▼
  
```

Cumulative run time  
DC link circuit voltage  
Max. inverter internal air temperature  
Max. heat sink temperature

```

I max = 0.00 A
CAP = 0.0%
MTIM = 14 h
MAINTENANC2/◆
  
```

Max. effective current value  
Internal capacitance of the DC bus capacitor  
Cumulative operation time of motor

```

TCAP = 11 h
      (61000h)
TFAN = 21 h
      (61000h)
MAINTENANC3/◆
  
```

Cumulative run time of capacitors on printed circuit board (Standard replacement intervals)  
Cumulative run time of cooling fan (Standard replacement intervals)

```

NST = 0
Wh = 0.0 kWh
PD = 0.0
MAINTENANC4/◆
  
```

Number of startups  
Cumulative power consumption  
Not applicable

```

NRR1 = 13 78
NRR2 = 0 0
NRO = 0 0
MAINTENANC5/◆
  
```

Number & Contents of RS485 communications errors  
Not applicable  
Not applicable

```

MAIN = 0600
KP = 8800
MAINTENANC6/◆
  
```

ROM version of the inverter  
ROM version of the keypad

```

OP1 = 0000
OPC = NONE
MAINTENANC7/▲
  
```

ROM version of the option  
Option name

Common operation:

To confirm data, call the desired page with ▲ / ▼ keys.

Press the  key to return to Menu.

Figure 3.15 Screen Transition for "5. MAINTENANC"

### 3.4.7 Reading alarm information -- Menu #6 "Alarm Information" --

Menu #6 "Alarm Information" in Programming mode allows you to view the information on the four most recent alarm conditions that triggered protective functions (in alarm code and the number of occurrences). It also shows the status of the inverter when the alarm condition arose.

Table 3.11 lists the details of the alarm information.

Table 3.11 Alarm Information Items

Item	Symbol	Description
Alarm history (last)	O/1	Alarm code and the number of occurrences
Alarm history (2 <sup>nd</sup> last)	-1	Alarm code and the number of occurrences
Alarm history (3 <sup>rd</sup> last)	-2	Alarm code and the number of occurrences
Alarm history (4 <sup>th</sup> last)	-3	Alarm code and the number of occurrences
Reference speed (final)	Fot1	Reference speed (final) commanded to the ASR (unit : Hz)
Output current	Iout	Output current value
Output voltage	Vout	Output voltage value
Calculated torque	TRQ	Reference torque
Reference speed (pre-ramp)	Fref	Reference speed (pre-ramp) (unit : Hz)
Rotational direction	FWD	Forward
	REV	Reverse
	Blank	Stopped
Running status	IL	Current limiting
	LU	Undervoltage detected (Inverter stopped)
	TL	Torque limiting
Cumulative operation time	TIME	Shows the cumulative operation time during which the inverter was powered ON.  When the total time exceeds 65,535 hours, the counter will be reset to 0 and the count will start again.
Number of startups	NST	Shows the total number of startups of the motor (number of times when the run command for the inverter was turned ON).  When the number of times exceeds 65,535 times, the counter will be reset to 0 and the count will start again.
DC link circuit voltage	EDC	Shows the DC link circuit voltage of the inverter's main circuit.
Inverter internal air temperature	TMPI	Shows the temperature inside the inverter.
Heat sink temperature	TMPF	Shows the temperature of the heat sink.
Input status at terminal	TRM	Input signal information at the control circuit terminals [FWD], [REV], [X1] to [X8], and [EN] (Highlighted when short-circuited; normal when open)
Input status at terminal via communications link	LNK	Input signal information via communications link [FWD], [REV], [X1] to [X8], [EN], (XF), (XR), and (RST) (Highlighted when 1; normal when 0)
Output status at terminal	-	Output signals information [Y1] to [Y5], and [30A/B/C] ((Highlighted when 1; normal when 0)
Multiple alarm 2	3	Alarm codes (2) that have simultaneously occurred ("----" is displayed if no alarms have occurred.)
Multiple alarm 1	2	Alarm codes (1) that have simultaneously occurred ("----" is displayed if no alarms have occurred.)
Alarm sub code	SUB	Auxiliary error code for causes of alarm

**Note** When the same alarm occurs repeatedly in succession, the alarm information for the first will be preserved as the alarm history (2<sup>nd</sup> last), and last occurrence as the alarm history (last). The information for other occurrences will be discarded. The number of consecutive occurrences will be preserved in the alarm history (2<sup>nd</sup> last).

## Basic key operation













- (1) When the inverter is powered on, it automatically enters Running mode. In Running mode, press the  key to enter Programming mode. The menu for function selection will appear.
- (2) Use the  /  keys to move the pointer  to "6. ALM INF."
- (3) Press the  key to call up the alarm list screen that shows information on the four most recent alarm conditions (alarm code and the number of occurrences for each alarm condition).
- (4) Use the  /  keys to select the alarm condition to be detailed.
- (5) Press the  key to display the alarm code on the LED monitor and the status data screen at the time of the alarm (one out of a total of 7 pages) on the LCD monitor.
- (6) Use the  /  keys to select the target item page and confirm the status data for that item.
- (7) Press the  key to return to the alarm list. Press the  key again to return to the menu.

Figure 3.16 shows the LCD screen transition for "6. ALM INF."

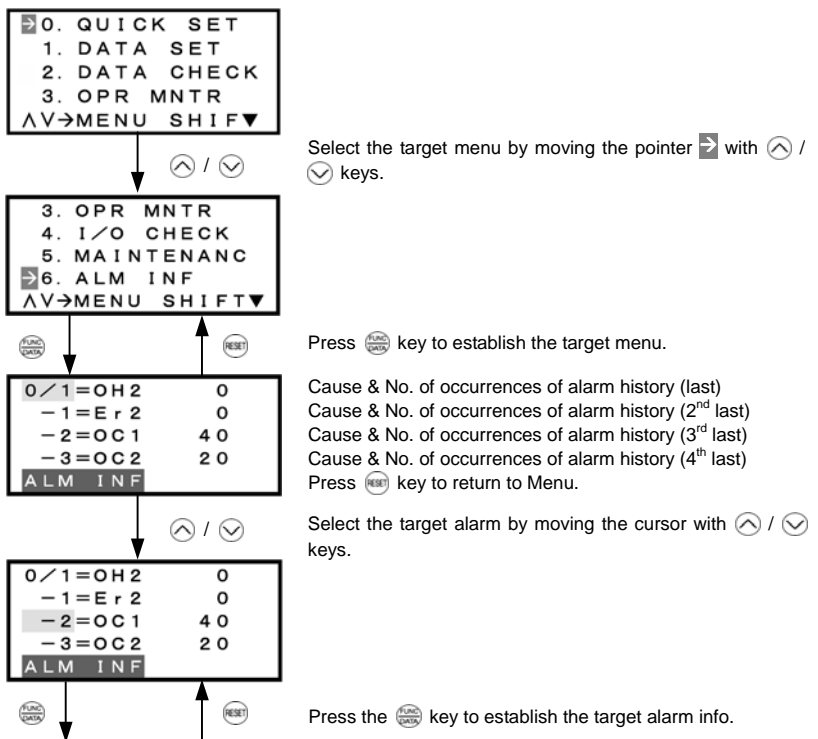

Figure 3.16 Screen Transition for "6. ALM INF"

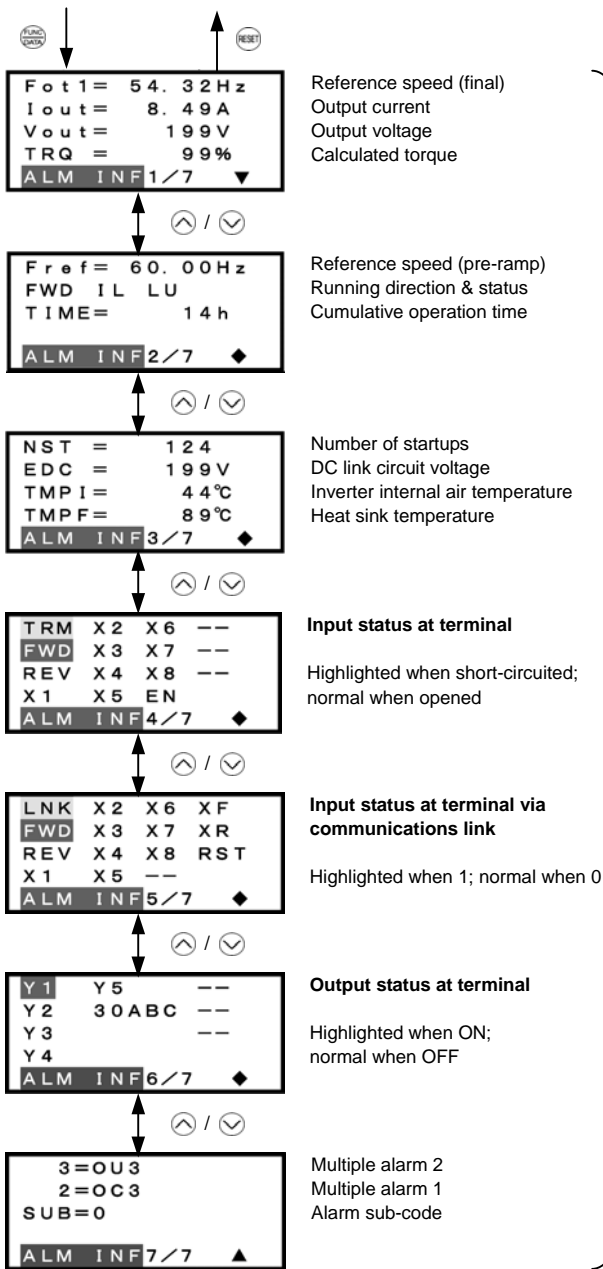













Figure 3.16 Screen Transition for "6. ALM INF" (continued)

### 3.4.8 Viewing cause of alarm -- Menu #7 "Alarm Cause" --

Menu #7 "Alarm Cause" in Programming mode allows you to view the information on the four most recent alarm conditions that triggered protective functions (in alarm code and the number of occurrences). It also shows the cause of each alarm.

#### **Basic key operation**

- (1) When the inverter is powered on, it automatically enters Running mode. In Running mode, press the  key to enter Programming mode. The menu for function selection will appear.
- (2) Use the  /  keys to move the pointer  to "7. ALM CAUSE."
- (3) Press the  key to call up the alarm list screen that shows information on the four most recent alarm conditions (alarm code and the number of occurrences for each alarm condition).
- (4) Use the  /  keys to select the alarm condition to be detailed.
- (5) Press the  key to display the alarm code on the LED monitor and the alarm cause screen (can be more than 1 page) on the LCD monitor.
- (6) Use the  /  keys to view the previous or next page.
- (7) Press the  key to return to the alarm list. Press the  key again to return to the menu.

 For the details of the suspected causes of these alarms, refer to the FRENIC-Lift Instruction Manual (INR-SI47-1038-E), Chapter 6 "TROUBLESHOOTING."

Figure 3.17 shows the LCD screen transition for "7. ALM CAUSE."

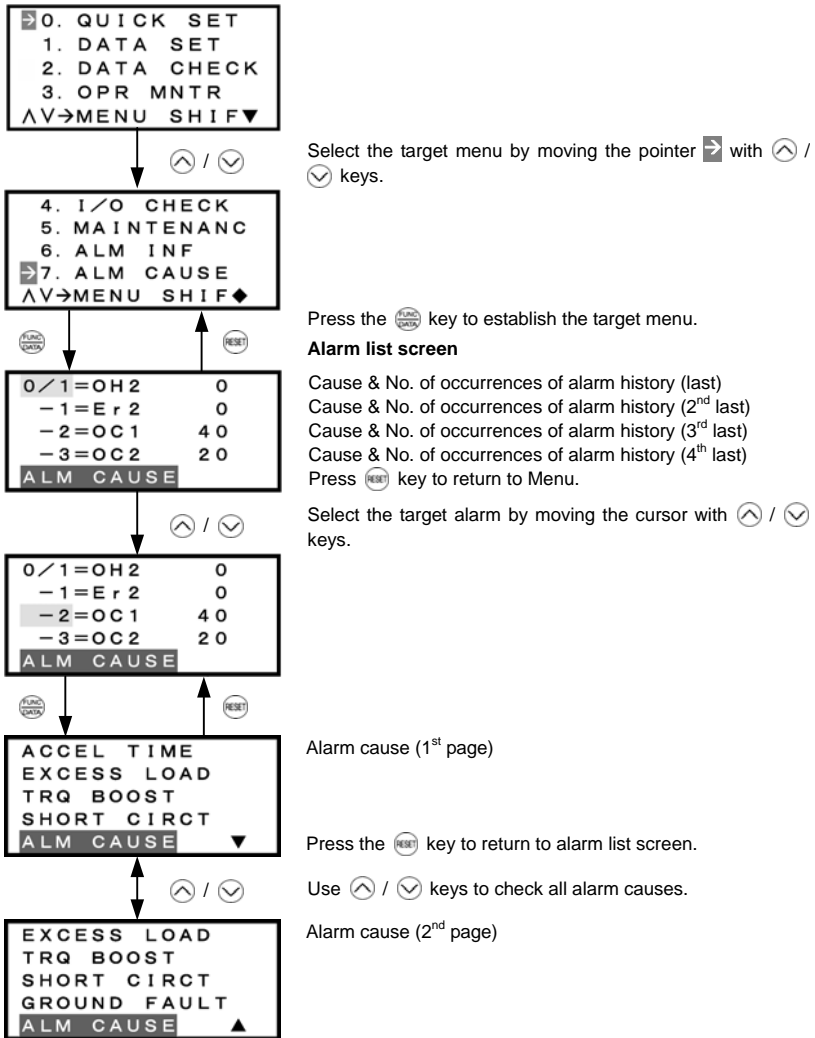
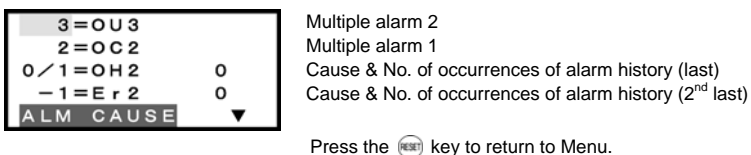

Figure 3.17 Screen Transition for "ALM CAUSE"

Pressing the ▲ key on the "Alarm list screen" allows you to select the alarm cause of a multiple alarm to check.





### 3.4.9 Data copying -- Menu #8 "Data Copying" --

Menu #8 "Data Copying" in Programming mode allows you to read function code data out of an inverter for which function codes are already set up and then to write such function code data altogether into another inverter, or to verify the function code data held in the keypad with the one in the inverter.

The keypad can hold three sets of function code data in three areas of its internal memory so that it can be used with three different inverters. You can read the function code data of an inverter into one of these memory areas or write the function code data held in one of these memory areas into the inverter you select. On the LCD screen, each set of function code data or memory area is given a name such as DATA 1 and DATA 2.

#### Basic key operation















- (1) When the inverter is powered on, it automatically enters Running mode. In Running mode, press the  key to enter Programming mode. The menu for function selection will appear.
- (2) Use the  /  keys to move the pointer  to "8. DATA COPY."
- (3) Press the  key to call up the data copy index screen (list of data copy operations).
- (4) Use the  /  keys to select the target operation (read, write, verify, or check).
- (5) Press the  key to establish the selected operation and then select data stored in the keypad.
- (6) Press the  key to establish the selection and perform the operation of your choice (for details, refer to the LCD screen transition diagram below).
- (7) Press the  key to return to the menu.

Figure 3.18 shows the LCD screen transition for "8. DATA COPY."

#### 1) Selecting Copy Operation

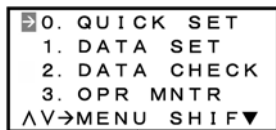

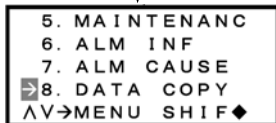

Select the target menu by moving the pointer  with  /  keys.

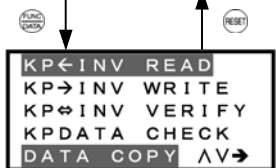

Press  key to establish the target menu.



#### List of data copy operations

Select desired operation by moving the cursor with  /  keys.

To return to Menu, press the  key.

Figure 3.18 Screen Transition for "8. DATA COPY"

Table 3.12 List of DATA COPY Operations

Operation	Description
Read: Read data	Reads out function code data from the inverter and stores it into the internal memory of the keypad.
Write: Write data	Writes the data held in the selected memory area of the keypad into the inverter.
Verify: Verify data	Verifies the data held in the keypad's internal memory against the function code data in the inverter.
Check: Check data	Checks the model information (format) and function code data held in the three memory areas of the keypad.

## 2) Read Operation

```

KP←INV READ
KP→INV WRITE
KP⇌INV VERIFY
KPDATA CHECK
DATA COPY ΔV→
    
```

### List of data copy operations

Select the target operation by moving the cursor with  $\uparrow$  /  $\downarrow$  keys.

Press the key to establish the target operation.

```

KP←INV READ
1:----
2:----
3:----
DATA COPY ΔV→
    
```

### Data selection screen

Select the target data by moving the cursor with  $\uparrow$  /  $\downarrow$  keys.

To go back to List of data copy operations, press the key.

Press key to establish the target data.

```

READ?
DATA1←INV
DATA2
DATA3
DATA COPY F/D
    
```

### Confirmation screen

If "Read" is actually performed, the data read out from the inverter will overwrite the data held in this memory area in the keypad. If OK, press the key.

To go back to Data selection screen, press the key.

Press the key to start Read operation.

```

READING...
DATA1←INV
DATA2
DATA3
■■■
    
```

### "In progress" screen

A bar indicating progress appears in the bottom.

Upon completion, Completion screen automatically appears.

```

READING END
DATA1←INV
DATA2
DATA3
DATA COPY RES
    
```

### Completion screen

This screen indicates that Read operation has completed successfully.

To go back to List of data copy operations, press the key.

### Error screens

```

ERROR
DATA1←INV
DATA2
DATA3
■■■
    
```

Pressing the or key during Read operation aborts the operation under way and displays this error. (Note) Once aborted, all the data held in the keypad's memory would be deleted.

```

ERROR
DATA1←INV
DATA2
DATA3
DATA COPY RES
    
```

If a communication error is detected between the keypad and the inverter, this error screen will appear.

Figure 3.19 Screen Transition for "READ"

**Note**

If an ERROR screen or ERROR Ver. screen appears during operation, press the key to reset the error condition. When Reset is complete, the screen will go back to List of data copy operations.

If a communications error occurs between the keypad and inverter during Read operation, all the data held in the keypad's memory will be deleted.

Note that, on the data selection screen for read, write, verify, and check operations, the values indicate the capacity of the inverters as listed below.

Table 3.13 Inverter Models on Data Selection Screen

Symbol	Inverter Model	Symbol	Inverter Model
5.5LM1-2	FRN 5.5 LM1S-2□	5.5LM1-4	FRN 5.5 LM1S-4□
7.5LM1-2	FRN 7.5 LM1S-2□	7.5LM1-4	FRN 7.5 LM1S-4□
11LM1-2	FRN 11 LM1S-2□	11LM1-4	FRN 11 LM1S-4□
15LM1-2	FRN 15 LM1S-2□	15LM1-4	FRN 15 LM1S-4□
18.5LM1-2	FRN 18.5 LM1S-2□	18.5LM1-4	FRN 18.5 LM1S-4□
22LM1-2	FRN 22 LM1S-2□	22LM1-4	FRN 22 LM1S-4□
		30LM1-4	FRN 30 LM1S-4□

\* A box (□) represents one or more alphanumerics.

### 3) Write operation

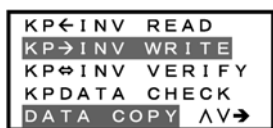

#### List of data copy operations

Select the target operation by moving the cursor with  $\uparrow$  /  $\downarrow$  keys.

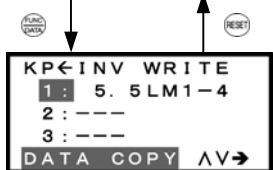

Press the  $\text{FUNC DATA}$  key to establish the target operation.

#### Data selection screen

Select the target data by moving the cursor with  $\uparrow$  /  $\downarrow$  keys.

To go back to List of data copy operations, press the  $\text{RESET}$  key.

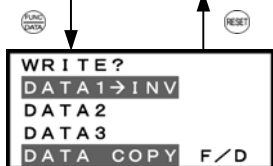

Press the  $\text{FUNC DATA}$  key to establish the target data.

#### Confirmation screen

If "Write" is actually performed, the selected data will overwrite the data held in the inverter. If OK, press the  $\text{FUNC OPEN}$  key.

To go back to Data selection screen, press the  $\text{RESET}$  key.



Press the  $\text{FUNC DATA}$  key to start Write operation.

#### "In progress" screen

A bar indicating progress appears in the bottom.

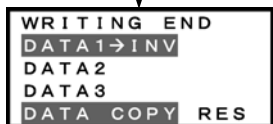

Upon completion, Completion screen automatically appears.

#### Completion screen



This screen indicates that Write operation has completed successfully.

To go back to List of data copy operations, press the  $\text{RESET}$  key.

Figure 3.20 Screen Transition for "WRITE"

## Error screens



Pressing the  or  key during Write operation aborts the operation under way and displays this error. Updating of the function code data in the inverter is incomplete, with some of it remaining old. Do not run the inverter in this state. Before running the inverter, redo the writing or perform initialization.



For safety considerations, the following situations are treated as an error:

- No valid data is found in the keypad's memory. (No Read operation has been performed since factory shipment; or, a Read operation has been cancelled or aborted.)
- The data held in the keypad's memory has an error.
- There is a mismatch in inverter's model number.
- A Write operation has been performed while the inverter is running.
- The inverter is data-protected.

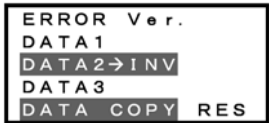

The function code data held in the keypad is incompatible with that in the inverter. (Either data may be non-standard or a version upgrade performed in the past may have made the keypad or inverter incompatible. Contact your Fuji Electric representative.)

Figure 3.20 Screen Transition for "WRITE" (continued)



If an ERROR screen or ERROR Ver. screen appears, press the  key. When Reset is complete, the screen will go back to List of data copy operations.



If an ERROR Ver. screen appears:

To stop Write operation, press the  key. When Reset is complete, the screen will go back to List of data copy operations.

To proceed to Write operation, press the  key. After completion of Write operation, be sure to perform Verify operation to check all of the unwritten functions codes and take necessary measures.

#### 4) Verify operation

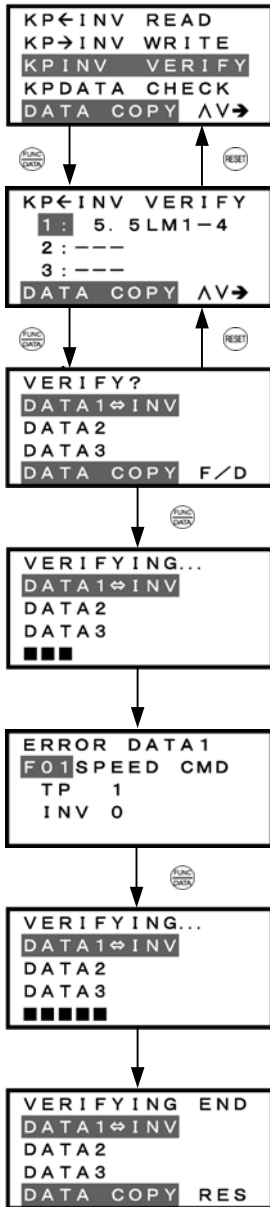

#### List of data copy operations

Select the target operation by moving the cursor with  $\uparrow$  /  $\downarrow$  keys.

Press the  $\text{FUNC DATA}$  key to establish the target operation.

#### Data selection screen

Select data to be verified by moving the cursor with  $\uparrow$  /  $\downarrow$  keys

To go back to List of data copy operations, press the  $\text{RESET}$  key.

Press the  $\text{FUNC DATA}$  key to establish the target data.

#### Confirmation screen

If OK, press the  $\text{FUNC DATA}$  key.

To go back to Data selection screen, press the  $\text{RESET}$  key.

Press the  $\text{FUNC DATA}$  key to start Verify operation.

#### "In progress" screen

A bar indicating progress appears in the bottom.

When a mismatch is found, the Verify operation is halted, with the function code and its data displayed on the LCD monitor. To resume the Verify operation from the next function code, press the  $\text{FUNC DATA}$  key again.

To resume Verify, press the  $\text{FUNC DATA}$  key.

#### "In progress" screen

A bar indicating progress appears in the bottom.

Upon completion, the screen automatically switches to the VERIFYING END.

#### Completion screen



This screen indicates that Verify operation has completed successfully.

To go back to List of data copy operations, press the  $\text{RESET}$  key.

Figure 3.21 Screen Transition for "VERIFY"

## Error screens



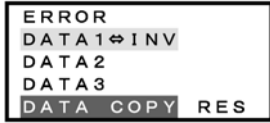

Pressing the  or  key during Verify operation aborts the operation under way and displays this error.(Note)



If the keypad does not have any valid data, this error screen will appear.

Figure 3.21 Screen Transition for "VERIFY" (continued)

 If an ERROR screen appears, press the  key to reset the error factor. When Reset is complete, the screen will go back to List of data copy operations.

## 5) Check operation

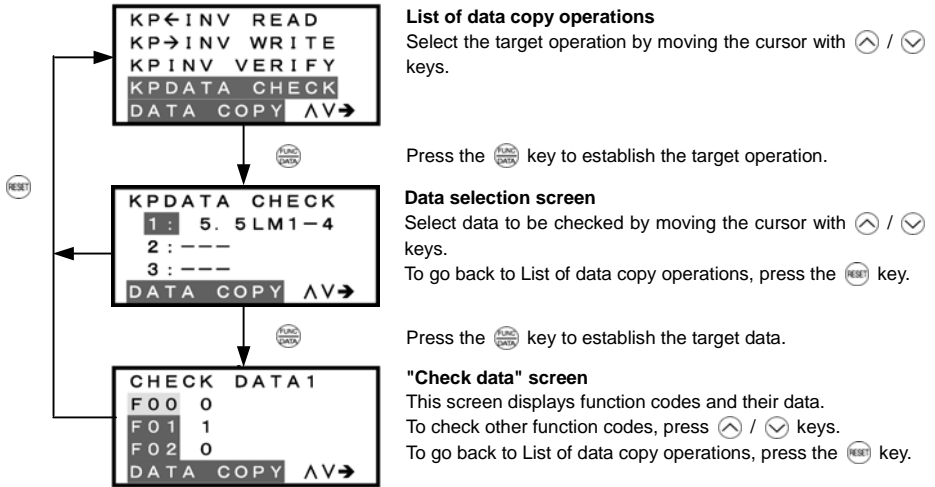
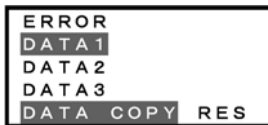

Figure 3.22 Screen Transition for "DATA CHECK"

### Error screen



If no valid data is found in the keypad, this error screen will appear. (Note)

Figure 3.23 Error Screen for "DATA CHECK"

**Note** If an ERROR screen appears during operation, press the  $\text{RESET}$  key to reset the error factor. When Reset is complete, the screen will go back to List of data copy operations.

### 3.4.10 Measuring load factor -- Menu #9 "Load Factor Measurement" --

Menu #9 "Load Factor Measurement" in Programming mode allows you to measure the maximum output current, the average output current, and the average braking power. There are two modes of measurement: "hours set" and "start to stop" modes. In the former mode, the measurement takes place for a specified length of time; in the latter mode, the measurement takes place from the start of running to the stop.

**Note** If the "start to stop" mode is entered while the inverter is running, the measurement takes place until it is stopped. If the "start to stop" mode is entered while the inverter is stopped, the measurement will take place from the next start of running until it is stopped.

#### Basic key operation









- (1) When the inverter is powered on, it automatically enters Running mode. In Running mode, press the  key to enter Programming mode. The menu for function selection will appear.
- (2) Use the  /  keys to move the pointer  to "9. LOAD FCTR."
- (3) Press the  key to get the measurement mode selection screen.
- (4) Use the  /  keys to select the measurement mode.
- (5) Press the  key to start the measurement. For "start to stop" mode, you will be prompted to enter a run command via a confirmation screen. For details, refer to the LCD screen transition chart.
- (6) Press the  key to return to the menu.

Figure 3.24 shows the LCD screen transition for "9. LOAD FCTR."

#### 1) Selecting measurement mode

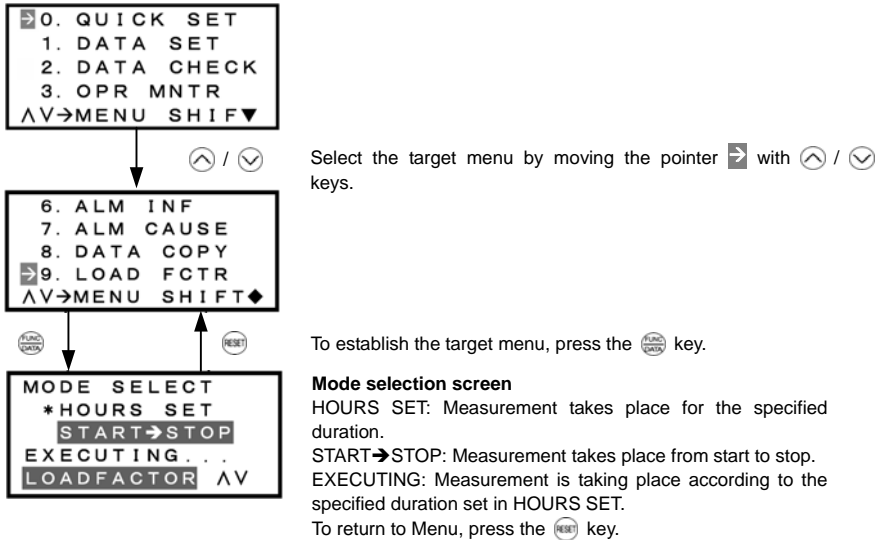
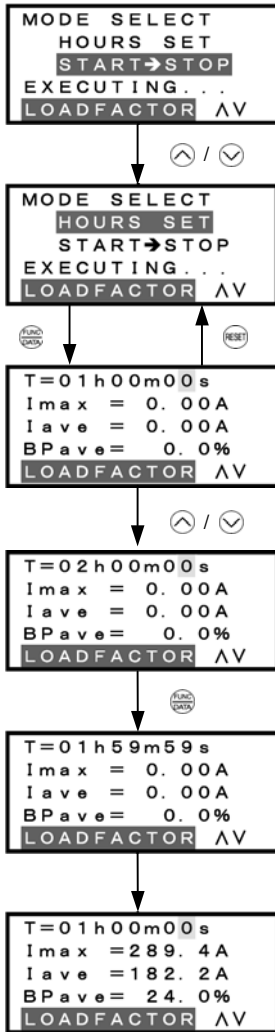

Figure 3.24 Screen Transition for Selecting Measurement Mode



## 2) Selecting "hours set" mode



### Mode selection screen

Select the target mode of measurement by moving the cursor with ▲ / ▼ keys.

Press the key to establish the target mode of measurement.

### Set time duration (Default: 1 hour)

To go back to Mode selection, press the key.

Set the duration with ▲, ▼, and keys.

Press the key to establish the duration and start measurement.

### Measurement in progress (remaining time)

While the measurement is in progress, the remaining time is displayed.

When the key is pressed or the measurement duration has elapsed, the measurement stops, displaying the results.

### Specified duration

Max. output current  
Average output current  
Average braking power

### [Display of measurement results]

Figure 3.25 Screen Transition for "Hours Set" Mode

### 3) Selecting "start to stop" mode

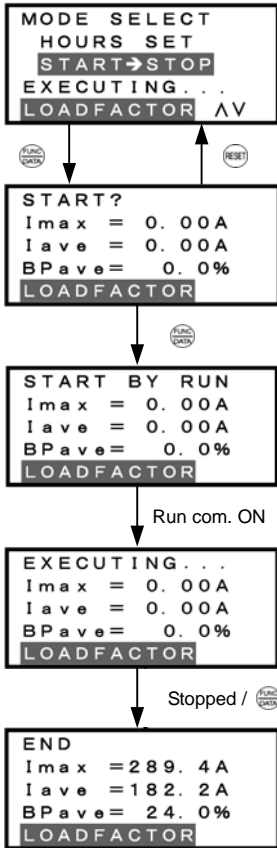

#### Mode selection screen

Select the target mode of measurement by moving the cursor with  $\uparrow$  /  $\downarrow$  keys.

#### Confirmation screen

If OK, press the  $\text{FUNCTION}$  key.

To go back to Mode selection, press the  $\text{RESET}$  key.

Press the  $\text{FUNCTION}$  key to signal "Ready."

#### Waiting for Run command (Standby for measurement)

Upon receiving Run command, the measurement will start.

If a Run command has already been received, this screen will be skipped.

Measurement will start upon receiving Run command.

#### Measurement in progress

The measurement will continue until the inverter is stopped.

To discontinue the measurement, press the  $\text{FUNCTION}$  key.

Measurement will stop when the inverter is stopped or you press the  $\text{FUNCTION}$  key.

#### Duration

Max. output current

Average output current

Average braking power

**[Display of measurement results]**

To return to Mode selection, press the  $\text{RESET}$  key.

Figure 3.26 Screen Transition for "Start to Stop" Mode

### 4) Going back to Running mode

While the measurement of the load factor is in progress, you can go back to the running mode by pressing the  $\text{PRG}$  key (or, to the Mode selection screen by pressing the  $\text{RESET}$  key).

In these cases, the measurement of the load factor will continue. You can go back to "9. LOAD FCTR" and confirm, on the Mode selection screen, that the measurement is in progress.

After the measurement has ended, you can view the results of the measurement by pressing the  $\text{FUNCTION}$  key on the Mode selection screen.



**Note** When the alarm occurs or the inverter power is turned off, the measurement result is cleared.

### 3.4.11 Changing function codes covered by Quick setup -- Menu #10 "User Setting" --

Menu #10 "User Setting" in Programming mode allows you to change the set of function codes that are covered by Quick setup.

#### Basic key operation









- (1) When the inverter is powered on, it automatically enters Running mode. In Running mode, press the  key to enter Programming mode. The menu for function selection will appear.
- (2) Use the  /  keys to move the pointer  to "10. USER SET."
- (3) Press the  key to call up the list of function codes.
- (4) Use the  /  keys to select the function codes to be added or deleted.
- (5) Press the  key to perform the addition or deletion.
- (6) Press the  key to return to the menu.

Figure 3.27 shows the LCD screen transition for "10. USER SET."

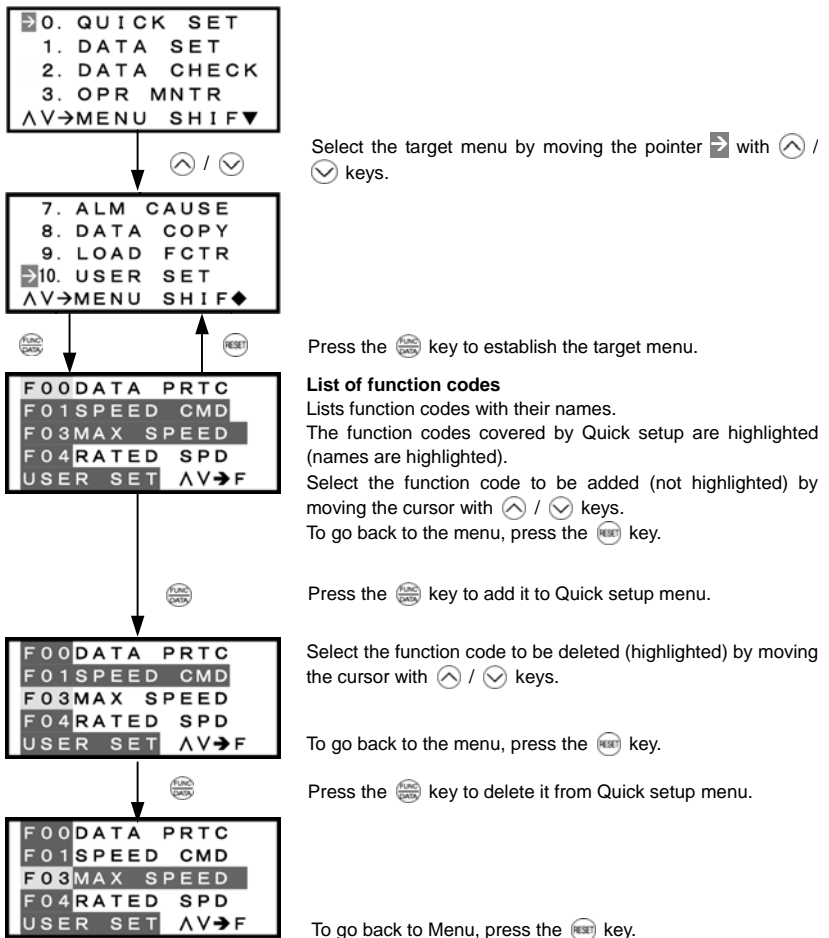

Figure 3.27 Screen Transition for Changing Quick Set Menu

### 3.4.12 Performing communication debugging -- Menu #11 "Communication Debugging" --

Menu #11 "Communication Debugging" in Programming mode allows you to view the data of communication-related function codes (S, M, W, X, and Z codes) to help debug programs for communication with host equipment.

#### Basic key operation

- (1) When the inverter is powered on, it automatically enters Running mode. In Running mode, press the key to enter Programming mode. The menu for function selection will appear.
- (2) Use the keys to move the pointer to "11. COMM DEBUG."
- (3) Press the key to call up the list of communication-related function codes.
- (4) Use the keys to move the cursor to the target function code.
- (5) Press the key to check the function code.
- (6) Press the key to return to the menu.

Figure 3.28 shows the LCD screen transition for "11. COMM DEBUG."

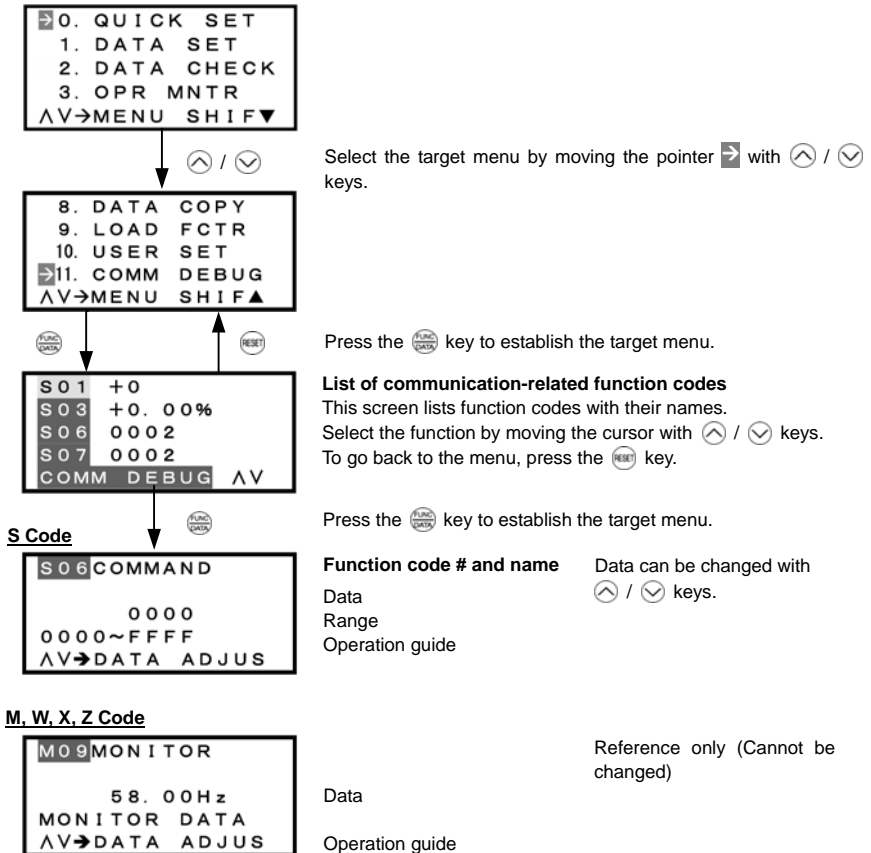

Figure 3.28 Screen Transition for "COMM DEBUG"

### 3.5 Alarm Mode

When a protective function is triggered, resulting in an alarm, the inverter automatically enters the alarm mode, displaying the alarm code on the LED monitor and the details of the alarm on the LCD monitor as shown below.

#### If there is no overlapping alarm



Most recent cause; No. of consecutive occurrences  
Cause of alarm  
Operation guide  
Operation guide

Figure 3.29 Without multiple Alarm

#### If there is an overlapping alarm

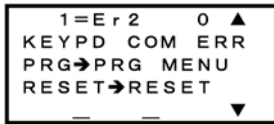

Most recent cause; No. of consecutive occurrences  
Cause of alarm (▲ is added if there is a multiple alarm.)  
Operation guide  
Operation guide

Figure 3.30 With Multiple Alarm

If there is a multiple alarm, you can view more detailed information by pressing the key.

In the examples below, "1 = Er2" corresponds to the first multiple alarm occurrence, and "2 = OH2" to the second multiple alarm occurrence.

#### ■ Display of alarm history

In addition to the most recent (current) alarm, you can view three recent alarms and any multiple alarms by pressing / keys while the most recent one is being displayed.

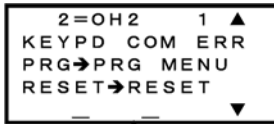

Multiple alarm; No. of consecutive occurrences  
Cause of alarm  
Operation guide  
Operation guide

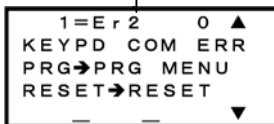

Most recent alarm; No. of consecutive occurrences  
Cause of alarm (▲ is added if there is an overlapping alarm.)  
Operation guide  
Operation guide

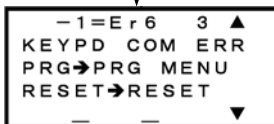

Alarm history (2<sup>nd</sup> last); No. of consecutive occurrences  
Cause of alarm  
Operation guide  
Operation guide

Figure 3.31 Screen Transition for Multiple Alarm History

■ Display of running status information at the time of alarm

Pressing the **ALM** key with an alarm code being displayed allows you to view the output frequency, output current, and other data concerning the running status. The data viewed is the same as with "6. ALM INF." Use **▲** and **▼** keys for scrolling pages within the menu.

Pressing the **PRG** key with the running status information being displayed returns to the display of the alarm code.

■ Transition to Programming mode

Pressing the **PRG** key with alarm information being displayed switches to Programming mode in which you can use a variety of features such as changing function code data.

■ Resetting alarm and transition to Running mode

Removing the cause of the alarm and pressing the **RESET** key will reset the alarm condition and switch the inverter back to Running mode.

Figure 3.32 summarizes the menu transition between these modes.

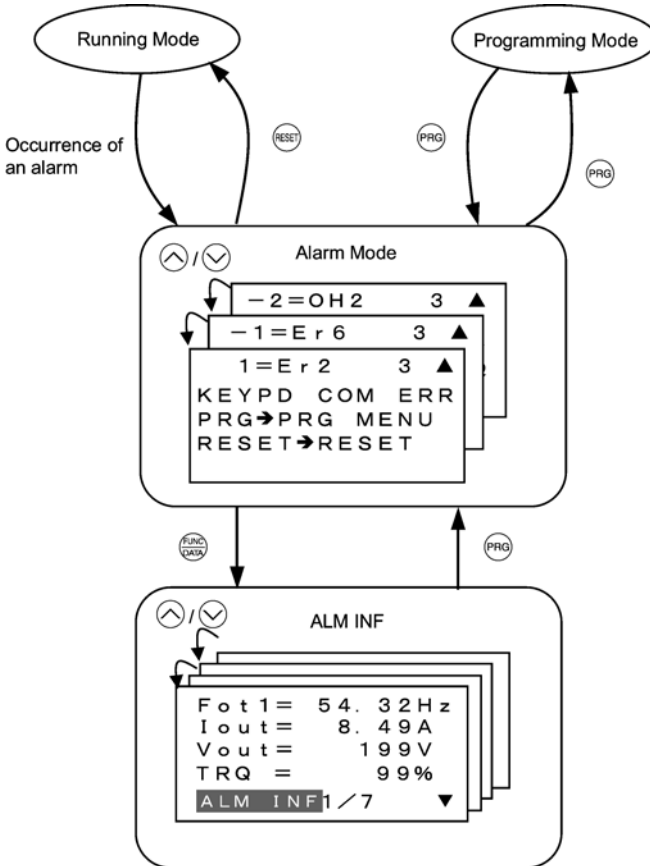



Figure 3.32 Menu Transition into/from Alarm Mode

### 3.6 Other Notes

#### 3.6.1 Tuning motor parameters



Selecting Menu #1 "Data Setting" in Programming mode and proceeding to function code P04 or L03 screen enables tuning operation.

##### ■ Motor tuning

Set function code P04 to "1" or "2," then press the  key.

```

P04M-TUN
0: INACTIVE
0~2
^V->DATA ADJUS
    
```

Use  /  keys to set P04 to either 1 or 2.

```

P04M-TUN
0: INACTIVE
1: AUTOTUNE1
0~2
^V->DATA ADJUS
    
```

Press the  key to establish the current tuning mode.

```

P04M-TUN
1: AUTOTUNE1
START BY RUN
COMMAND
    
```

Wait for a run command.

Run command ON

```

P04M-TUN
1: AUTOTUNE1
EXECUTING . . .
    
```

Wait for the completion of tuning of the motor parameters. (Note 1)

End of tuning

```

P04M-TUN
1: AUTOTUNE1
CLOSE BY RUN
COMMAND OFF
    
```

Run command OFF

Turn the run command off. (The run command given by the keypad or the link operation is automatically turned off.)

```

P06M-I o
P07M-%R 1
P08M-%X
P09M-SLIP d %
^V->FN CODE SH
    
```

Tuning completes. The lead-through on the keypad ends the tuning process and moves to the next function code P06.

Figure 3.33 Screen Transition for Motor Tuning



(Note 1) Time for tuning: Approx. 15 sec when P04 = 1  
Approx. 25 sec when P04 = 2

■ Magnet pole position tuning

Set function code L03 to the target tuning and press the  key.

```
L03 P. P. TUNE
      0
0~5
ΛV→DATA ADJUS
```

 / 

Press  /  keys to select the target tuning.

```
L03 P. P. TUNE
      0
      1
0~5
ΛV→DATA ADJUS
```



Press the  key to establish the current tuning mode.

```
L03 P. P. TUNE
      3
START BY RUN
COMMAND
```

Wait for a run command.

Run command ON

```
L03 P. P. TUNE
      3
EXECUTING . . .
```

Wait for the completion of tuning.

End of tuning

```
L03 P. P. TUNE
      3
CLOSE BY RUN
COMMAND OFF
```

Run command OFF

Turn the run command off. (The run command given by the keypad or the link operation is automatically turned off.)

```
L04 P. P. OFFSET
L05 MAKER
L06 MAKER
L09 Nr FILTER
ΛV→FN CODE SH
```

Tuning completes. The lead-through on the keypad ends the tuning process and moves to the next function code L04.

Figure 3.34 Screen Transition for Magnet Pole Position Tuning

 The setting range of L03 may vary depending upon the inverter's ROM version. For details about the setting range, refer to the FRENIC-Lift Instruction Manual (INR-SI47-1038-E).



### 3.6.2 Password protection

Function code H99 (Password) allows you to enter a password that protects your function code data from illegal access or modification by a third party. When the password protection is enabled, you cannot read nor write F00 data (Data Protection) from any method except the keypad. In addition, even when the password protection is temporarily disabled, you cannot read F00 or H99 data from any methods except the keypad.

The password protection can be temporarily canceled with F00.

When the password protection is enabled:		
Accessible/changeable	Not accessible or changeable	Accessible/changeable partially
3. OPR MNTR 4. I/O CHECK 5. MAINTENANC 6. ALM INF 7. ALM CAUSE 9. LOAD FCTR 11. COMM DEBUG	8. DATA COPY 10. USER SET	0. QUICK SET 1. DATA SET 2. DATA CHECK  <b>Note:</b> The function code list can be displayed, but data of function codes cannot be accessed or changed except F00 and H03.

#### ■ Entering password (Enabling the password protection)

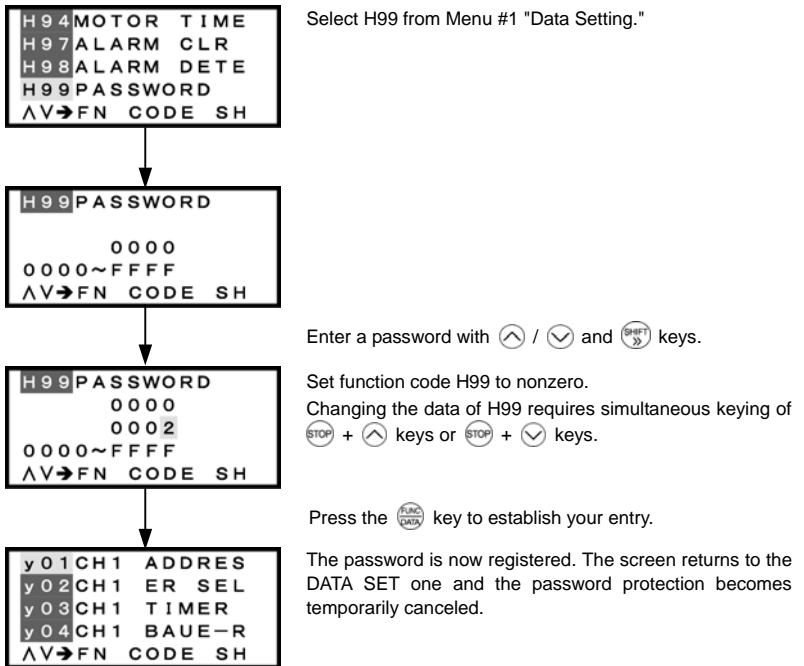
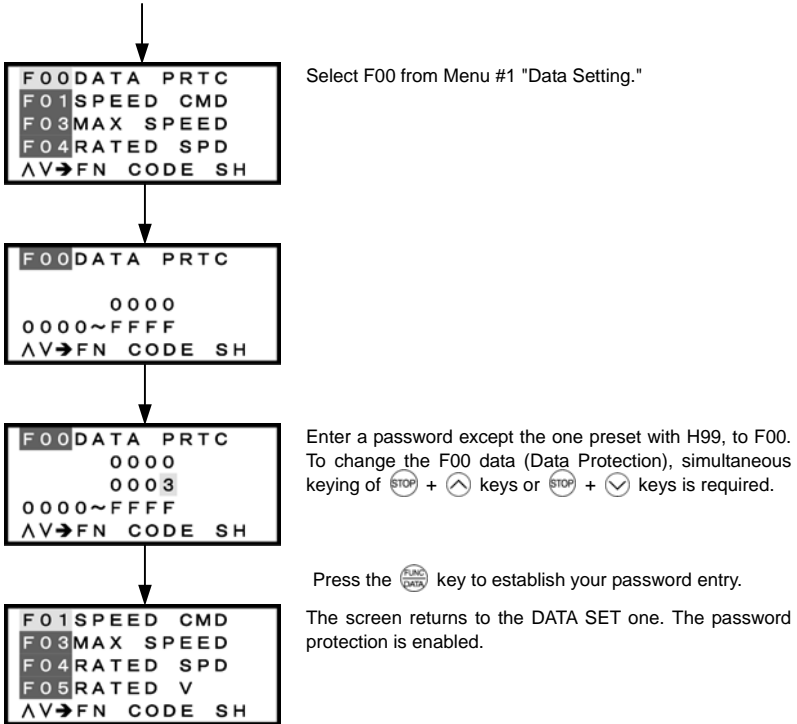

Figure 3.35 Screen Transition for Password Entry

**Note** Once a password is registered, the password protection becomes temporarily canceled. To enable the password protection, follow the procedures on the next page.

■ Enabling the password protection

Enter a password with the procedure given on the previous page.



**Tip** Other ways to enable password protection:

In addition to the above procedure, turn the inverter power off or leave the inverter with the password temporarily canceled for at least four hours and then switch the inverter to Running mode or Menu.

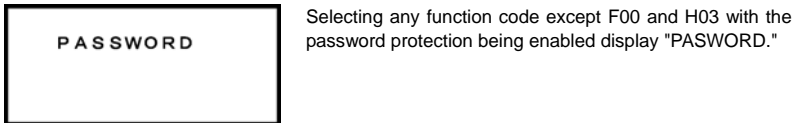
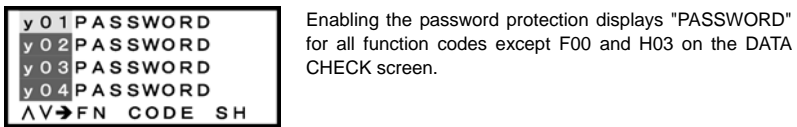

Press the (RESET) key to return to the DATA CHECK screen.

Press the (PRNG) key to return to Running mode.

Figure 3.36 Screen Transition for Setting Password Protection

■ The password protection temporarily canceled

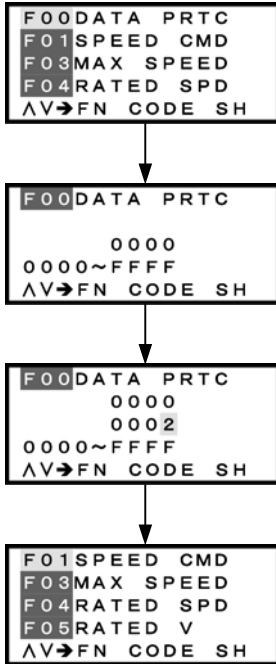

Select F00 from Menu #1 "Data Setting."

Enter the password preset with H99 to F00.  
To change the data of F00 (Data Protection), simultaneous keying of + keys or + keys is required.

Press the key to establish your password entry.

The screen returns to the DATA SET one. The password protection is temporarily canceled.

Figure 3.37 Screen Transition for the Password Protection Temporarily Canceled



With the password protection temporarily canceled, setting H99 data to a value other than 0000 enables you to register a new password.

### ■ Canceling the password protection

The password protection temporarily canceled with the procedure given on the previous page.

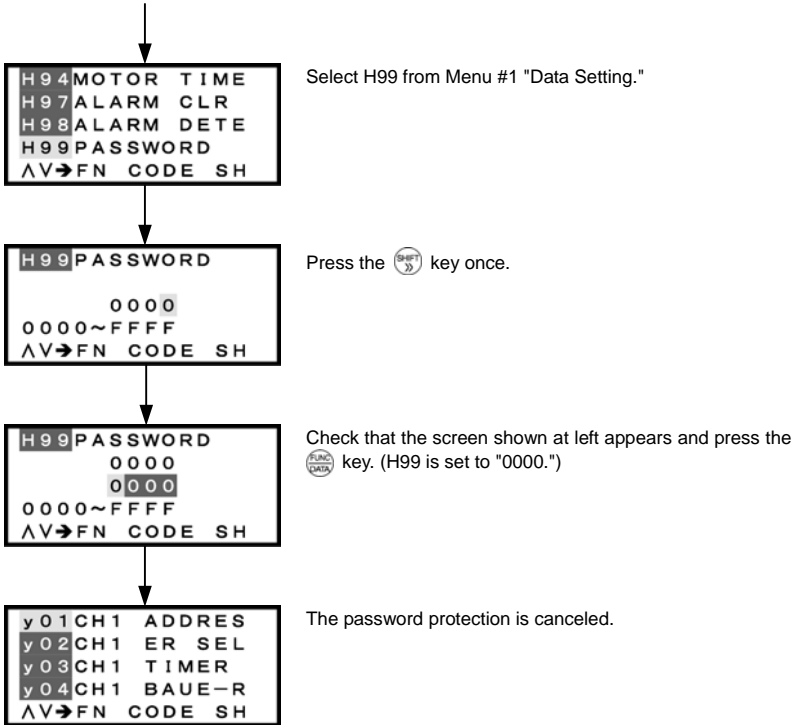



Figure 3.38 Screen Transition for Canceling Password Protection

 **Tip** If you forget your password, you can reset the password protection by performing "Initializing" with H03.

## CAUTION

Initializing with H03 resets all the function code data to the factory defaults. Be sure to restore the proper settings that match the specifications of the system.

**Accidents or injuries may result.**

### 3.6.3 Connecting to other inverter series



Connecting the multi-function keypad TP-G1-CLS / TP-G1-ELS to an inverter other than FRENIC-Lift series displays this ERROR screen.

# Chapter 4 SPECIFICATIONS

## 4.1 General Specifications

Table 4.1 summarizes the general specifications of the multi-function keypad TP-G1-CLS / TP-G1-ELS.

Table 4.1 General Specifications

Item	Specifications	Remarks
Enclosure	Front side: IP40; Rear side: IP20	
Environment	Indoor only. Shall be free from corrosive gases, flammable gases, dust, and direct sunlight.	
Ambient temperature (during operation)	-10 to +50°C	
Ambient humidity	5 to 95% RH (no condensation)	
Altitude	1000 m or below	
Vibration	3 mm (max.) : 2 - 9 Hz 9.8 m/s <sup>2</sup> : 9 - 20 Hz 2 m/s <sup>2</sup> : 20 - 55 Hz 1 m/s <sup>2</sup> : 55 - 200 Hz	
Ambient temperature (during storage)	-25 to +65°C	
Ambient humidity (during storage)	5 to 95% RH (no condensation)	
External dimensions	See the figure below.	
Mass	129 g	

### External dimensions

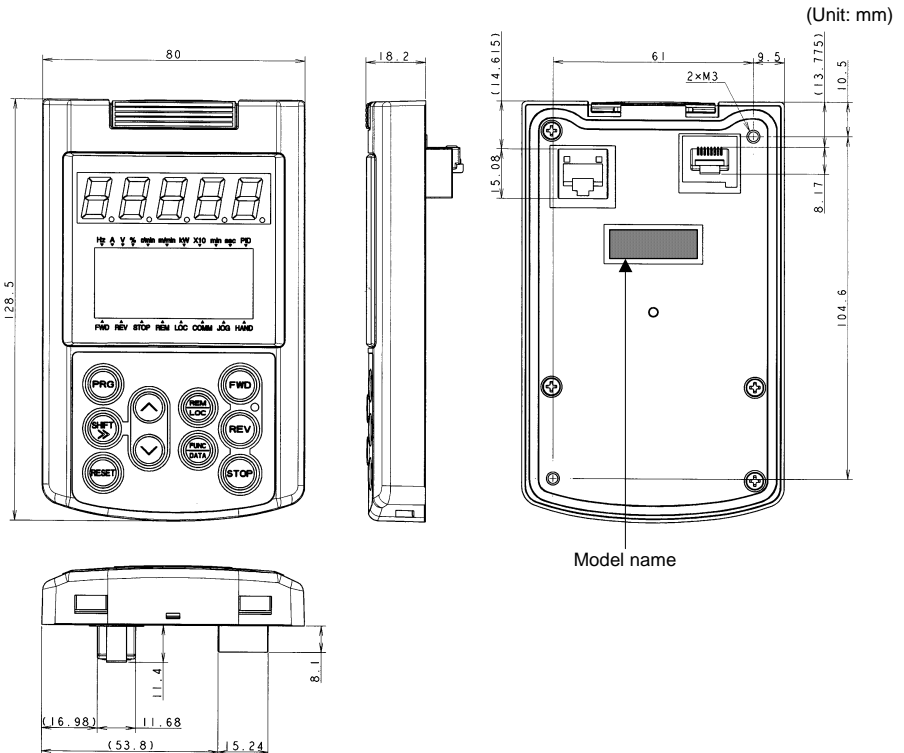

## 4.2 Communication Specifications

Tables 4.2 and 4.3 summarize the communication specifications.

Table 4.2 Hardware Specifications

Item	Specifications	Remarks
No. of inverters connected	One inverter for one multi-function keypad	
Connection cable	Shall meet the US ANSI/TIA/EIA-568A Category 5 standard (10BASE-T/100BASE-TX, straight).	A remote operation extension cable is available as an option (CB-5S, CB-3S, or CB-1S, depending on the distance).
Maximum communication distance	20 m	
Connector	RJ-45 connector	See Table 4.3.

Table 4.3 RJ-45 Connector Pin Assignment

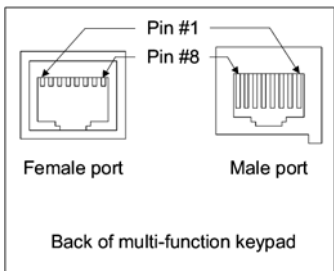
Pin #	Signal name	Description	Remarks
1, 8	Vcc	DC power source for multi-function keypad (5 V)	
2, 7	GND	Signal ground	
3, 6	NC	Unassigned (reserved)	
4	DX -	RS485 communication data ( - )	
5	DX +	RS485 communication data ( + )	

**Note** SW3 for the terminating resistor on the control circuit board in the inverter must be set to OFF (open).

## 4.3 Transmission Specifications

Table 4.4 summarizes the transmission specifications.

Table 4.4 Transmission Specifications

Item	Specifications	Remarks
Area code	No need to specify.	There is no need to specify function codes y01 through y10 for RS485 communication, which will be ignored anyway.
Communication protocol	Modbus-RTU	
Synchronization system	Asynchronous Start-stop bit	
Communication system	Half-duplex	
Communication speed (Baud rate)	19200 bps	
Parity	Even parity	
Stop bit length	1 bit	
Error checking	CRC-16	

## **Multi-function Keypad "TP-G1-□LS"**

---

### **Instruction Manual**

First Edition, September 2005

Second Edition, June 2006

Third Edition, May 2007

Fuji Electric FA Components & Systems Co., Ltd.

---

The purpose of this manual is to provide accurate information in the handling, setting up and operating of Multi-function Keypad TP-G1-CLS / TP-G1-ELS for the FRENIC-Lift series of inverters. Please feel free to send your comments regarding any errors or omissions you may have found, or any suggestions you may have for generally improving the manual.

In no event will Fuji Electric FA Components & Systems Co., Ltd. be liable for any direct or indirect damages resulting from the application of the information in this manual.

---

## **Fuji Electric FA Components & Systems Co., Ltd.**

Mitsui Sumitomo Bank Ningyo-cho Bldg., 5-7, Nihonbashi, Odemma-cho, Cyuo-ku, Tokyo, 103-0011, Japan

Phone: +81 3 5847 8011 Fax: +81 3 5847 8172

URL <http://www.fujielectric.co.jp/fcs/>

---