

OVERVIEW



SOLUTIONS FOR THE TRANSPORTATION SECTOR



OUR APPROACH



Being one of our three strategic business sectors, Camozzi offers the **transportation** industries a wide range of products. These products are ready for use in the harshest conditions, are reliable and efficient, in order to **keep you moving**.

In close cooperation with our customers and partners, we develop and produce standard products and customised solutions, always focussing on three main targets: **high performance**, **smart design** and **excellent quality**.

Developing products that can operate under extreme temperatures, in dirty or corrosive environments and resistant to high mechanical loads and vibrations, is the mission that drives our experienced and motivated engineers.

Our **worldwide customer base** consists of leading OEMs, Tier 1 System Suppliers, Component Manufacturers, Body Builders and well-known players in the Aftermarket and Repair business.

We always follow one leading principle: **"The customer first - Always"**.

OUR CUSTOMER CHANNELS

Vehicle Manufacturers

Whether you are a large-scale industrial producer with JIS and JIT requirements, or a smaller specialist maker with unlimited design flexibility, we can provide components and systems to enhance your products.

System Suppliers / Body Builders

As experts in your field, you deliver complex systems & sub-systems as an integral part of the final vehicle. Or, you may take an OEM chassis and create custom vehicles for your customers. Fire trucks, waste management vehicles or any other vehicle class, our components create differentiation and added value.

Component manufacturers

Your products are highly specialised and are essential to complete 'the big picture'. OEM quality, reliability and stable supply lines are mandatory to be your partner.

Aftermarket & Distribution

High quality, an attractive product offering and excellent availability, are key factors contributing to the success of your business.



OUR APPLICATIONS

Camozzi Automation`s long history in the **transportation** sector has brought us into the supply chain of many different vehicle classes, including **Road, Off Highway** and **Rail** operations.

We are active in all the major application fields, including **Chassis, Powertrain, Cabin & Body,** and **Mobile Automation.**

Our offering starts from **fittings** for multiple fluids like air, fuel, water, oil or grease and extends over a wide range of control **valves** for gases & fluids, to pneumatic and electric **actuators**, filters, **regulators** and other **complementary products.**

This comprehensive range makes us **the right partner for your project.**

Connection or Actuation, On/Off or Proportional, Analogue or CAN-BUS, IATF 16949 or IRIS, **we talk your language.**

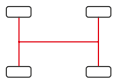

CHASSIS

Applications on the vehicle base frame. No matter if it runs on rails, road or entirely off-road, we offer high performance technologies that provide you with safe braking, optimised traction, cooling and a smooth ride.

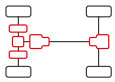

POWERTRAIN

The toughest application group on any vehicle. Environments with high temperatures, NVH and extensive cycle times require outstanding performance and robust design. Challenge accepted.

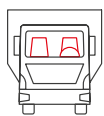

CABIN & BODY

Applications in direct contact with drivers, passengers, operators or simply an integral part of the vehicle. Our components support your safety, comfort and functionality.

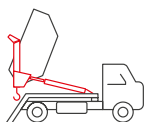

MOBILE AUTOMATION

Vehicles are not stationary, they move from one place to another. In many cases the mobility is not the primary task of the vehicle. Special purpose units added to many vehicles are demanding and involve complex design processes.

Whether you are looking for solutions to pilot your hydraulics, connect your lubrication system, proportionally control air pressures and flows, or simply move steps, handrails or aerodynamic devices with pneumatic or electric actuators, we are your partner.

VEHICLE TYPES SUPPORTED

Truck & Trailer



Bus & Coach



Off Highway



Passenger Car & Light Duty Commercial Vehicles

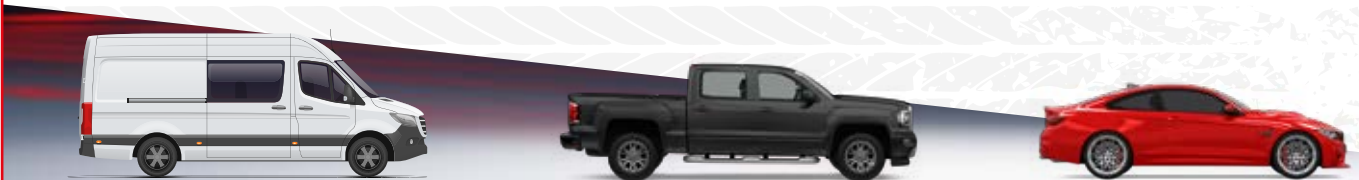

Railway

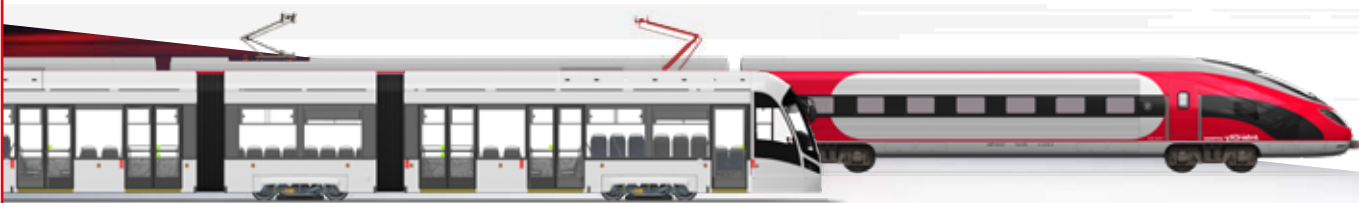



CUSTOMISED SOLUTIONS FOR YOUR DIGITAL JOURNEY

Every day we are developing our offering in products, services, and quality further. The keys to achieve this are strong customer relationships, **attention to detail** and a total commitment to providing **the best solution possible**.

This approach naturally leads to the understanding that standard sometimes is not enough, and together with our customers we often take the decision to jointly go the extra mile.

Camozzi Automation offers its customers a broad range of **customised solutions** which reduce assembly time, the number of parts or integrate multiple functions into a new and customer-specific component.

We create added value by combining mechanical and digital technologies, and we routinely bridge the gap that differentiates 'the good' from 'the best'. This philosophy has always been an integral part of our business approach, and the experience gained over the years is a solid foundation for **supporting our partners all the way from idea to implementation**.

The last ten years, Camozzi Automation has invested significantly in **digitalisation**. And our growing development team is dedicated to ensuring that the company remains at the forefront of technology.

Today, most of our new products and solutions for the industrial automation sector have been developed with a clear focus on digital innovation and energy efficiency.



They include technologies such as **IoT, Industry 4.0 and predictive maintenance** solutions that all help to increase our customers' productivity and success. Our digital know-how in the 'immobile sector' has made it easier for us to accommodate projects and product developments for the rapidly evolving digital journey of the transportation sector.

If you are looking for a valve block, electric drive or proportional regulator that connects and communicates via a digital BUS with your vehicle's body computer or other devices, we are ready to develop the right product for you. From autonomous driving and operation to new propulsion systems, **over data mining & cloud services to precision farming**, we look forward to supporting your journey and taking you further.

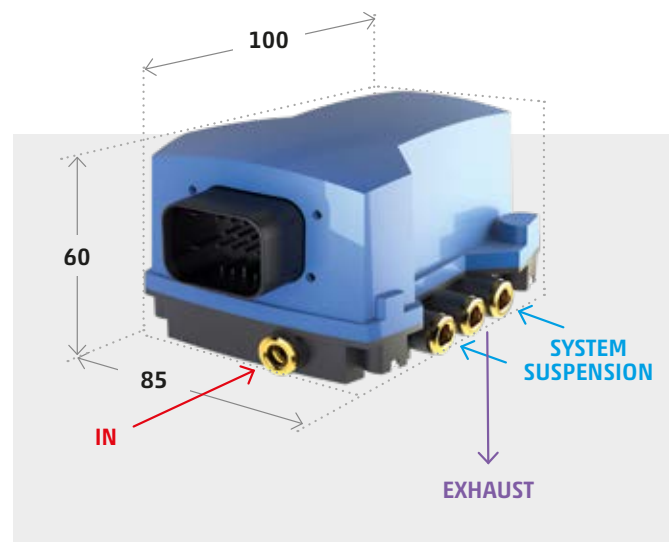

Truck & Trailer

Commercial vehicles is a demanding field of application. Trucks must perform in various climatic and environmental conditions.

Maximum uptime and reduced cost of ownership are the primary needs. Components for this market, no matter if provided to the OEM, the body builder or the aftermarket, need to be **reliable** and **robust** in order to keep wheels turning and **your business going**.



More Applications?
Scan the QR code

OUR COMPONENTS CAN BE FOUND IN

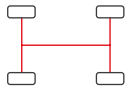

CHASSIS

- Air brake systems
- Air suspension systems
- Tyre inflation systems
- Lift axle

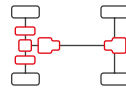

POWERTRAIN

- Automated manual transmission
- Cooling
- Fuel systems

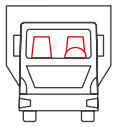

CABIN & BODY

- Seat suspension
- Cabin cleaning
- Adjustable steering column

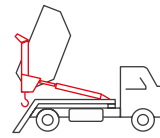

MOBILE AUTOMATION

- Load fixation
- Tailgate drives
- Expandable container chassis
- Bumper lift
- Central lubrication
- Retractable handrail

CUSTOMISED SOLUTION

Camozzi multichannel valve block for pneumatic piloting of the hydraulic system in a heavy-duty hook loader truck.

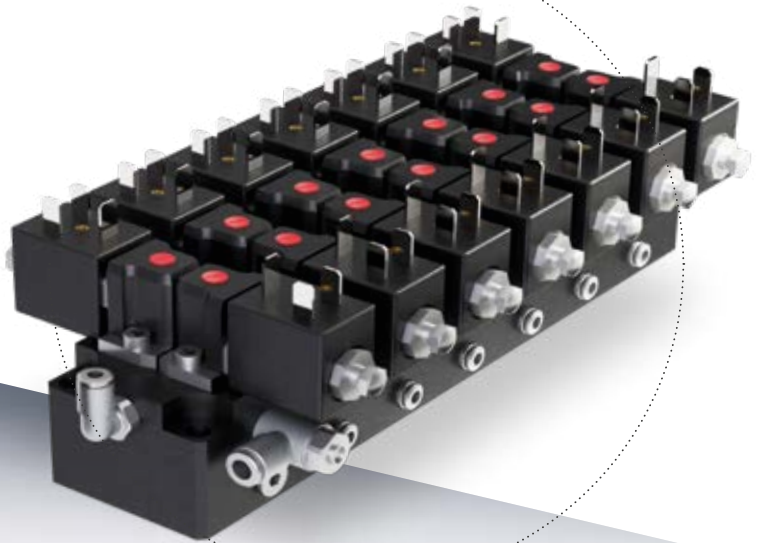

Bus & Coach

Buses and Coaches are key to the future of public transport. Cities around the world need to find answers to the growing demand for individual mobility of their inhabitants.

At the same time, traveling across countries is getting ever more popular, for a generation on the move. Camozzi Automation has extensive know-how and a long history in providing systems and solutions for the bus segment. **Comfort, safety and reliability** are the driving factors in this industry and we always strive to provide **excellence in quality and service.**



More Applications?
Scan the QR code

OUR COMPONENTS CAN BE FOUND IN

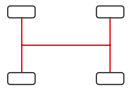

CHASSIS

- Air brake systems
- Air suspension systems

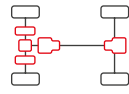

POWERTRAIN

- Cooling & heating
- Fuel systems
- Fire extinguishing systems

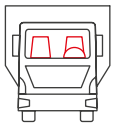

CABIN & BODY

- Seat suspension
- Door drives
- Adjustable steering column
- Automatic doorsteps

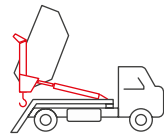

MOBILE AUTOMATION

- Locking & actuation functions
- Fresh & wastewater management

CUSTOMISED SOLUTION

Camozzi drive and pneumatic control valve for bus doors.



Off Highway

Leaving paved roads creates additional challenges for vehicles and drivers. At the same time, it enables early development and adoption of new technologies as there is more freedom and fewer constraints compared to vehicles running on rail and road.

Smart farming and autonomous operation are proof that this vehicle class is at the forefront of technology. No matter if you are harvesting crops, tearing down old walls or building new infrastructures, agricultural and construction vehicles are key for what is coming ahead on our way in the future. Camozzi components connect brakes, fuel, lubrication or low-pressure hydraulic lines. They control pneumatically piloted hydraulic systems, coolant flows and manage tyre pressures.

Camozzi Automation is the **right partner on and off the road.**



More Applications?
Scan the QR code

OUR COMPONENTS CAN BE FOUND IN

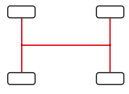

CHASSIS

- Air brake systems
- Air suspension system
- Tyre inflation system

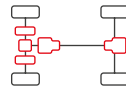

POWERTRAIN

- Automated manual transmission
- Cooling & heating
- Fuel systems

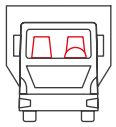

CABIN & BODY

- Seat suspension
- Cabin cleaning
- Adjustable steering column
- Air intake

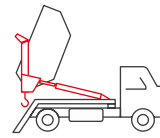

MOBILE AUTOMATION

- Central lubrication
- Piloting of hydraulic systems
- Locking functions
- Low pressure hydraulic lines

CUSTOMISED SOLUTION

Camozzi active tyre inflation control system, including ECU, control panel for dashboard, valve block & wheel valves.



Passenger Car & Light Duty Vehicles

The Automotive Sector has always been an area of constant change, great challenges and exciting innovations. Now we are about to witness the next step changes.

Autonomous or assisted driving brings mobility and safety to a new level.

New propulsion technologies such as hybrids, battery and fuel cell drive trains are becoming the new standard. Camozzi is working with customers in projects for chassis functionalities in special vehicles, comfort enhancement, or passive safety features of next generation vehicles.



More Applications?
Scan the QR code

OUR COMPONENTS CAN BE FOUND IN

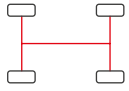

CHASSIS

- Air suspension systems

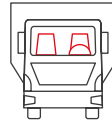

CABIN & BODY

- Passive safety
- Passenger comfort

CUSTOMISED SOLUTION

Air suspension valve block (Aftermarket solution), for highly flexible kneeling functions in vans and commercial vehicles.

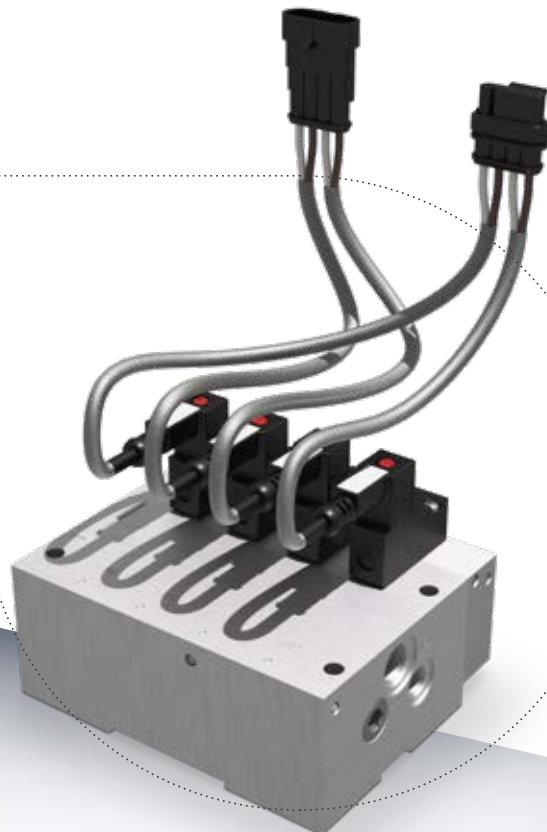

Railway

The Railway Industry is looking back on a long history as key technology for the transportation of people and goods over long distances. It has enabled individual travelling by connecting destinations across countries, beyond borders and even continents.

Today the achievable **efficiency and capacity** of this vehicle type puts it again back into the focus for future transportation means.

Actuation and control of doors, flaps, couplings and pantographs, management of fresh and wastewater, the main brake system, sanding, greasing and many other applications are served with Camozzi components and solutions.

Our offering is in line with the latest regional and global standards and meets the specifications of our world leading customer base.

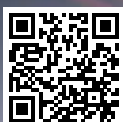

More Applications?
Scan the QR code

OUR COMPONENTS CAN BE FOUND IN

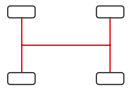

CHASSIS

- Air brake systems
- Air suspension systems
- Greasing systems
- Sanding systems

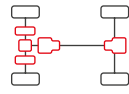

POWERTRAIN

- Power switching
- Pantograph actuation

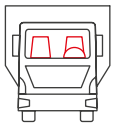

CABIN & BODY

- Seat suspension
- Fresh air intake
- Door drives (int. & ext.)
- Automatic doorsteps
- Passenger ramps
- Vacuum toilets
- Nose actuation
- Fresh & wastewater management

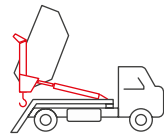

MOBILE AUTOMATION

- Actuation of wagon connection
- Flap actuation
- Mirror movement

CUSTOMISED SOLUTION

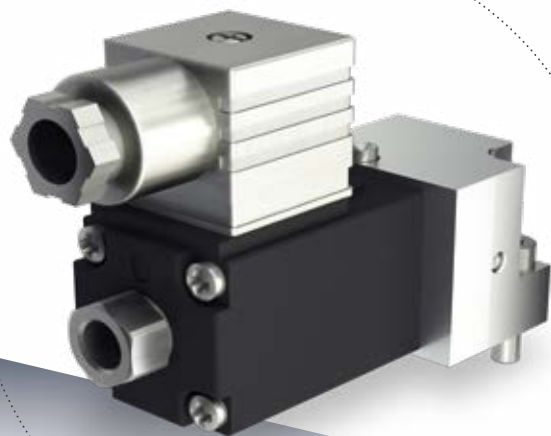

Valve assembly in control cabinet for the main airbrake system in freight trains.





OUR PRODUCT RANGE FOR THE TRANSPORTATION SECTOR

PNEUMATIC ACTUATION



• International standard cylinders

	MATERIAL	BORES	FUNCTION	KEY FEATURES
 Series 16, 23, 24, 25 Mini-cylinders	Anodized aluminium end-caps stainless steel profile and rod	ø 8, 10, 12, 16, 20, 25, 32 mm	Single and double-acting	<ul style="list-style-type: none"> • ISO 6432 • Cushioning: Mechanical / Adjustable / Auto • Extended working temperature
 Series 40 and 41 Cylinders	Coated AL end-caps, stainless steel AISI 420B or chrome plated steel piston rod, anodized AL tube and profile	ø 160, 200, 250, 320 mm	double-acting	<ul style="list-style-type: none"> • ISO 15552 • Cushioning: Adjustable • Ready for harsh environments
 Series 63 ISO 15552 cylinders	Coated aluminium end-caps, stainless steel AISI 420B or AISI 304 or AISI 316 piston rod, anodized AL tube and profile	ø 32, 40, 50, 63, 80, 100, 125 mm	single and double-acting	<ul style="list-style-type: none"> • ISO 15552 • Extended working temperature • Ready for harsh environment • Options: Mechanical end locks, rubber bellows

• Compact cylinders

 Series QN Short-stroke cylinders	Aluminium body and other materials in stainless steel	ø 8, 12, 20, 32, 50, 63 mm	single-acting	<ul style="list-style-type: none"> • Compact and lightweight
 Series QL Short-stroke cylinders	Anodized AL end-caps and profile, stainless steel piston rod	ø 12, 16, 20, 25, 32, 40, 50, 63, 80, 100 mm	double-acting	<ul style="list-style-type: none"> • Compact and lightweight

• Stainless steel cylinders

 Series 90 Stainless steel cylinders ISO 15552	Stainless steel AISI 316	ø 32, 40, 50, 63, 80, 100 and 125 mm	Single and double-acting	<ul style="list-style-type: none"> • ISO 15552 • Cushioning: Adjustable • Ready for harsh environment
 Series 94, 95 Stainless steel mini-cylinders	Stainless steel AISI 316	ø 16, 20, 25 mm	Single and double-acting	<ul style="list-style-type: none"> • ISO 6432 • Cushioning: Mechanical / Adjustable • Ready for harsh environment
 Series 97 Stainless steel cylinders	Stainless steel AISI 304	ø 32, 40, 50, 63 mm	Single and double-acting	<ul style="list-style-type: none"> • Cushioning: Mechanical / Adjustable • Ready for harsh environment



• Rodless cylinders

 Series 50 Rodless cylinders	Anodized aluminium end-caps and profile	ø 16, 25, 32, 40, 50, 63, 80 mm	Double-acting	<ul style="list-style-type: none"> • Cushioning: Adjustable
 Series 54 Rodless cylinders	Anodized aluminium end-caps and profile	ø 25, 32, 40, 50, 63 mm	Double-acting	<ul style="list-style-type: none"> • Compact design • Cushioning: Adjustable • Guiding: Standard / sliding

• Cylinders not according standards

 Series 27 Roundline cylinders	Aluminium end-caps, Inox AISI 304 tube, stainless steel piston rod	ø 20, 25, 32, 40, 50, 63 mm	Double-acting	<ul style="list-style-type: none"> • Lightweight • High mounting flexibility
---	---	--------------------------------	---------------	--

• Rotary cylinders



 Series 69 Rotary cylinders	Aluminium end-caps, anodized aluminium profile	ø 32, 40, 50, 63, 80, 100, 125 mm	Double-acting	<ul style="list-style-type: none"> • Adjustable swivel angle • Angles: 90° / 180° / 270° / 360°
 Series ARP Rotary actuators	aluminium end-caps, anodized aluminium profile	1, 3, 5, 10, 12, 20, 35, 55, 70, 100, 150, 250, 400	Spring return (single-acting), double-acting	<ul style="list-style-type: none"> • Namur VDI/VDE 3845 connections • ISO 5211 valve interface • Swivel angles: 90°

ELECTRIC ACTUATION



• Electromechanical cylinders

	SIZES	FUNCTION	KEY FEATURES
 Series 6E Electromechanical cylinder	32, 40, 50, 65, 80, 100 mm	Multi-position system with motion transmission by means of a recirculating ball screw	<ul style="list-style-type: none"> High forces ISO 15552 Protection Class: IP40 / IP65

• Electromechanical axes









 Series 5ES...TBL	50, 65, 80 mm	Multi-position system with integrated recirculating ball bearing guide and motion transmission with toothed belt	<ul style="list-style-type: none"> High dynamic actuator Protection Class: IP40 Stroke: Up to 6m
 Series 5ES...BS	50, 65, 80 mm	Multi-position system with integrated recirculating ball bearing guide and motion transmission with recirculating ball screw	<ul style="list-style-type: none"> High accuracy High forces Protection Class: IP40

• Drives and Motors

 Series DRCS Drives for Stepper motors	one-size for different motors	Can be controlled in frequency (step and direction), digital I/O and serial CANopen protocol	<ul style="list-style-type: none"> Easy control through Camozzi software 127 programmable position & motion profiles 	
 Series MTS Motors for electric actuation	Nema 23, 24, 34	Stepper motor	<ul style="list-style-type: none"> Protection class: IP65 Suitable for high torque & low speed applications 	







VALVES AND SOLENOID VALVES

• Direct and indirect acting 2/2 - 3/2 solenoid valves











	MATERIAL	CONNECTIONS	FUNCTION	KEY FEATURES
 Series K8 Direct acting solenoid valves	Brass - Stainless Steel	Cartridge seat in manifold	2/2 NC - 3/2 NC - 2/2 NO 3/2 NO - 3/2 UNI	<ul style="list-style-type: none"> Compact design (8mm) Manifold mounting Low power consumption
 Series K8B Pilot operated solenoid valves	Brass - Stainless Steel - Aluminium	Cartridge seat in manifold - M7 - Flanged	2/2 NC - 2/2 NO 3/2 NC - 3/2 NO	<ul style="list-style-type: none"> Compact design (8mm) High flow Manifold mounting Low power consumption Membrane isolation technology
 Series K8DV Media separated solenoid valves	PEEK	Cartridge seat in manifold Flanged	2/2 NC	<ul style="list-style-type: none"> Isolation Technology Compact design (8mm) Suitable for inert & corrosive gases and liquids Low power consumption
 Series K Direct acting solenoid valves	PBT	Flanged	2/2 NC - 3/2 NC - 3/2 NO	<ul style="list-style-type: none"> Compact design (10mm) Manifold mounting Low power consumption
 Series KL - KLE Direct acting solenoid valves	PBT	Flanged ISO 15218	2/2 NC - 3/2 NC 3/2 NO - 3/2 UNI	<ul style="list-style-type: none"> Compact design (10mm) Manifold mounting High flow Low power consumption
 Series KN Direct acting solenoid valves	PBT	Flanged ISO 15218	3/2 NC - 3/2 NO - 3/2 UNI	<ul style="list-style-type: none"> Compact design (10mm) Manifold mounting Low power consumption
 Series W Direct acting solenoid valves	PBT	Flanged ISO 15218	3/2 NC - 3/2 NO	<ul style="list-style-type: none"> Compact design (15mm) Manifold mounting Low power consumption Electric connection: Flying leads or DIN EN 175 301-803
 Series P Direct acting solenoid valves	PBT	Flanged ISO 15218	3/2 NC - 3/2 NO	<ul style="list-style-type: none"> Compact design (15mm) Manifold mounting Low power consumption
 Series PL Direct acting solenoid valves	PBT - PPS	Flanged ISO 15218	2/2 NO - 3/2 NC 3/2 NO - 3/2 UNI	<ul style="list-style-type: none"> Compact design (15mm) Manifold mounting Low power consumption Suitable for low temperatures till - 55°

VALVES AND SOLENOID VALVES





• Direct and indirect acting 2/2 - 3/2 solenoid valves

	MATERIAL	CONNECTIONS	FUNCTION	KEY FEATURES
 Series PN Direct acting solenoid valves	PBT	Flanged ISO 15218	3/2 NC	<ul style="list-style-type: none"> • Compact design (15mm) • Manifold mounting • Low power consumption
 Series PD Direct acting solenoid valves	Brass - Aluminium - POM	Flanged - M5 threads	2/2 NC	<ul style="list-style-type: none"> • Compact design (15mm) • Manifold mounting • Low power consumption
 Series PDV Media separated solenoid valves	PEEK	Flanged	2/2 NC	<ul style="list-style-type: none"> • Compact design (15mm) • Suitable for inert & corrosive gases and liquids • Low power consumption
 Series 6N Direct acting solenoid valves	Brass - Aluminium	G1/8, G3/8 threads Ø4mm push-in fitting CNOMO interface	2/2 NC - 3/2 NC - 3/2 NO	<ul style="list-style-type: none"> • Robust design (30mm) • Manifold mounting • Suitable for low temperatures till - 55° • Multiple electric connector options • With sealed cables up to IP69K
 Series CFB Solenoid valves	Brass	G1/8 ... G2 threads	2/2 NC - 2/2 NO - 3/2 NC	<ul style="list-style-type: none"> • Multipurpose valve with brass body • For gases and fluids • Multiple electric connector options • With sealed cables up to IP69K
 Series CFB INOX Stainless steel Solenoid valves	Stainless steel 316L	G1/8 ... G1/2 threads	2/2 NC - 3/2 NC	<ul style="list-style-type: none"> • Multipurpose valve with stainless steel body for corrosive gases & liquids • Ready for harshest conditions

• Solenoid, pneumatic and manifold valves





 Series 8 Pneumatic operated cartridge valves	PPS - Brass - Aluminium	Cartridge seat in manifold	2/2 NC - 3/2 NC	<ul style="list-style-type: none"> • 3 standard sizes • Manifold mounting • High flow
 Series 8 Pneumatically and electropneumatically operated valves	Brass - Aluminium	G1/8 - G1/4 - G3/8 threads	2/2 NC - 3/2 NC	<ul style="list-style-type: none"> • 3 standard sizes • Manifold mounting • High flow
 Series EN Valves and solenoid valves	Aluminium body	G1/8 - G1/4	5/2 - 5/3 CC - 5/3 CO - 5/3 CP	<ul style="list-style-type: none"> • Designed for harsh conditions
 Series D Valves and solenoid valves VB version	Aluminium body	M7 - G1/4 - G3/8	3/2 NC - 3/2 NO - 2x3/2 NO 2x3/2 NC - 1x3/2 NO + 1x3/2 NC 5/2; 5/3 CC, CO, CP	<ul style="list-style-type: none"> • Light and compact design • M8 connection
 Series 3 Valves and solenoid valves	Aluminium body	G1/8 - G1/4	3/2 NC - 3/2 NO - 2x3/2 NO 2x3/2 NC - 1x3/2 NO + 1x3/2 NC 5/2; 5/3 CC, CO, CP	<ul style="list-style-type: none"> • Multipurpose valve for pneumatics • Perfect choice for Mobile Automation
 Series 4 Valves and solenoid valves	Aluminium body	G1/8 - G1/4 - G3/8 - G1/2	3/2 - 5/2 - 5/3-way CC, CO	<ul style="list-style-type: none"> • Multipurpose valve • High flow • Robustness in critical conditions (i.e. low temperatures)
 Series 9 Valves and solenoid valves	Aluminium body	ISO 5599-1	5/2 and 5/3-way CC CO	<ul style="list-style-type: none"> • Highly flexible valve design
 Series NA Valves and solenoid valves	Aluminium body	NAMUR	3/2-way NC, NO - 5/2-way 5/3-way CC, CO, CP	
 Series ASX Angle seat valves	Stainless steel 316	1/4 ... 4" with BSPP/BSPT/ NPT threads, flanged, welding ends, tri-clamp	2/2 NC - 2/2 NO 2/2 Double Acting	<ul style="list-style-type: none"> • High flow design • Body in stainless steel • Suitable for water, air, steam or other inert or corrosive fluids & gases • High temperatures up to 220°C
 Series ASP Angle seat valves	Brass	3/8 ... 2-1/2" BSPP threads	2/2 NC - 2/2 NO 2/2 Double Acting	<ul style="list-style-type: none"> • High flow design • Suitable for water, air, steam or other inert and corrosive liquids & gases

• Mechanical and manual valves







	MATERIAL	PORT SIZES	FUNCTION
 Series 2 Mechanically operated minivalves	Aluminium body	M5, Ø4mm push-in fitting	3/2
 Series 1 and 3 and 4 Manually operated minivalves	Aluminium body	G1/8, G1/4	3/2 - 5/2 - 5/3 ways CC, CO
 Series 3 and 4 Mechanically operated minivalves	Aluminium body	G1/8, G1/4	3/2, 5/2 way
 Series VMS Mechanically operated minivalves	Aluminium body	M5, G1/8, G1/4, G3/8, G1/2, G3/4	3/2-way

VALVES AND SOLENOID VALVES

• Automatic Valves

	MATERIAL	PORT SIZES	FUNCTION
 Series VNR Unidirectional valves	Brass body	M5, G1/8, G1/4, G3/8, G1/2, G3/4, G1, Ø4; Ø6; Ø8; Ø10; Ø12	Unidirectional valve
 Series VSO and VSC Quick exhaust valves	Brass body	Series VSO: M5, G1/8, cartridge Ø4 Series VSC: G1/8, G1/4, G1/2	Quick exhaust valve
 Mod. VMR 1/8-B10 Adjustable overpressure exhaust valve	Brass body	G1/8	Overpressure exhaust valve
 Series VBO - VBU Blocking valves	Brass body	G1/8 - G1/4 - G3/8 - G1/2	Blocking valve

• Flow Control valves





	MATERIAL	PORT SIZES	FUNCTION
 Series SCU, MCU, SVU, MVU, SCO, MCO Flow control valves	Stainless steel body and regulation screw (M5)	M5 - G1/8 - G1/4 - G3/8 - G1/2	Unidirectional and bidirectional banjo flow control regulators
 Series PSCU, PMCU, PSVU, PMVU, PSCO, PMCO Flow control valves	Stainless steel body and regulation screw (M5)	M5 - G1/8 - G1/4 - G3/8	Unidirectional and bidirectional banjo flow control regulators
 Series TMCU, TMVU, TMCO Flow control valves	Brass - technopolymer NBR	G1/8 - G1/4 - G3/8 - G1/2	Unidirectional and bidirectional banjo flow controllers
 Series GSCU, GMCU, GMVU, GSCO, GMCO Flow control valves	Stainless steel body and screws M5	M5, G1/8 and G1/4	Unidirectional and bidirectional banjo flow controllers
 Series RFU and RFO Flow control valves	Aluminium body	M5, G1/8, G1/4, G3/8 and G1/2	Unidirectional and bidirectional controller
 Series 28 Flow control valves	Nickel-plated brass body	G1/8, G1/4, G3/8, G1/2	Bidirectional
 Series 29 Mini ball valves for pneumatics and industrial fluids	Brass valve body	G1/8, G1/4, G3/8, G1/2, R1/8, R1/4	2/2-way, 3/2-way with exhaust

• Silencers

 Series 2901 - 2903, 2921 - 2931 - 2938, 2939 - 2905	Brass, coppering steel, polyethylene	M5, G1/8, G1/4, G3/8, G1/2, G3/4, Ø4; 6; 8; 10; 12 mm	Silencer
--	--------------------------------------	---	----------

VALVES ISLAND

CANopen | READY







 Series 3 PLUG-IN valve islands, Multipole and Fieldbus	Aluminium body	Valve = G1/8 Manifold = G3/8	5/2 - 5/3 CC - 5/3 CO 5/3 CP - 2x3/2 NO 2x3/2 NC 1x3/2 NO + 1x3/2 NC	• Robust valve island based on Series 3
 Series D - Size 1 Valve islands, Multipole and Fieldbus	Aluminium body subbase size 1: polymer	Outlet 2 and 4, size 10,5 mm: tube Ø 4, Ø 6	2x3/2 NO - 2x3/2 NC 1x3/2 NO + 1x3/2 NC 5/2; 5/3 CC, CO, CP	• Lightweight and compact design
 Series D - Size 2 Valve islands, Multipole and Fieldbus	Aluminium body subbase size 2: polymer	Outlet 2 and 4, size 16 mm: tube Ø6, Ø8, Ø10	2x3/2 NO - 2x3/2 NC 1x3/2 NO + 1x3/2 NC 5/2; 5/3 CC, CO, CP	• Lightweight and compact design
 Series D - Size 4 Valve islands, Multipole and Fieldbus	Aluminium body and individual subbase	Outlet 2 and 4, size 25: threaded G 3/8	2x3/2 NO - 2x3/2 NC 1x3/2 NO + 1x3/2 NC 5/2; 5/3 CC, CO, CP	• High flow rate • Metal body • Robust design
 Series D - Size 5 Valve islands, Multipole and Fieldbus	Aluminium body subbase size 1 & 2: polymer	Size 10,5: tube Ø 4, Ø 6 Size 16: tube Ø 6, Ø 8, Ø 10	2x3/2 NO - 2x3/2 NC 1x3/2 NO + 1x3/2 NC 5/2; 5/3 CC, CO, CP	• Combination of flow types in one valve island • Compact dimensions

PROPORTIONAL TECHNOLOGY





• Proportional flow valves

	MATERIAL	PORT SIZES	FUNCTION	KEY FEATURES
 Series AP Directly operated proportional valves	Brass body, PVDF body (size 16mm only) NBR, FKM, EPDM seals	M5 - G1/8 - flange body	2/2 NC - Flow valve	• Multipurpose proportional valve
 Series CP Directly operated and pressure compensated proportional solenoid valves	Size 16mm stainless steel body Size 20mm stainless steel body and brass nozzle, FKM seals	Cartridge	2/2-way NC - Flow valve	• High dynamics • High flow
 Series 130 Electronic control device for proportional valves	Polycarbonate	Screw	Driver	• Closed loop control





• Proportional pressure regulators

 Series OF Open Frame Controller Modular proportional regulator	NBR, FKM, EPDM seals	G1/8	2/2-way - 3/3-way	• Pressure, Flow and Position control • CANopen version	
 Series K8P Electronic proportional micro regulator	Technopolymer body	Flange - Sub base tube $\varnothing 4$	Pressure regulator 3 ways NC	• Compact design • High precision	
 Series MX-PRO Proportional pressure regulator and proportional flow valve	Aluminium body	G1/2	Pressure regulator 3 ways NC	• High flow	
 Series PRE Proportional pressure regulator with CoilVision® technology	Aluminium body, FKM seals	G1/4 - G3/8 - 1/4NPTF	Pressure regulator 3 ways NC Pressure regulator 3 ways NO	• Configuration flexibility • Integrated diagnostic and predictivity • Manifold version	
 Series PME Proportional pressure regulator	Aluminium body, FKM seals	G1/4 - G3/8 - 1/4NPTF	Pressure regulator 3 ways NC Pressure regulator 3 ways NO	• Configuration flexibility • Manifold version • NFC function • CANopen version	

AIR TREATMENT

	MATERIAL	PORT SIZES	FUNCTION	KEY FEATURES
 Series MX Assembled FRL	Aluminium body	MX2: G3/8 - G1/2 - G3/4 MX3: G3/4 - G1	Filters, Regulators and Lubricators	• High reliability • Easy maintenance
 Series MC Assembled FRL	Zama, NBR, technopolymer	G1/4 - G3/8 - G1/2	Filters, Regulators and Lubricators	• Great modularity • Easy maintenance
 Series MD Assembled FRL	Polyamide body	With interchangeable cartridges: 1/8, 1/4 and 3/8 threaded or integrated with super-rapid fitting for tube with $\varnothing 6, 8$ and 10 mm	Filters, Regulators and Lubricators	
 Series N	Brass body	G1/8, G1/4	Filters, coalescing filters and activated carbon filters, Pressure regulators, Lubricators, Filter regulators	• Resistant to aggressive fluids (version with metal bowl)

• Pressure regulators

 Series CLR Pressure microregulators	Brass body	G1/4, G1/8	Pressure regulators	• Compact and lightweight
 Series TC Pressure microregulators	Brass body	Cartridge construction, G1/8 and 1/8 NPTF	Pressure microregulators	• Compact and lightweight
 Series M Pressure microregulators	Brass body	G1/8, G1/4	Pressure microregulators	• Ready for low working temperatures till -40°C
 Series T Pressure microregulators	Technopolymer body	G1/8 and G1/4	Pressure microregulators	• Extremely lightweight
 Series PR Precision regulators with manual override	Anodized aluminium	Size 1 ports: G1/4 Size 2 ports: G1/4, G3/8	Pressure regulator	• Multi-diaphragm design for high stability and precision

FITTINGS

	MATERIAL	PORT SIZES	FUNCTION	KEY FEATURES	
	Series 1000 Push-on fittings	Nickel Plated Brass	4 - 12mm tube BSPT and BSPP threads	Connection for plastic tubing	<ul style="list-style-type: none"> • Metallic sealing system
	Series 2000 Adaptors	Nickel Plated Brass	BSPP, BSPT, NPTF, Metric, UNF threads	Threaded adaptors	<ul style="list-style-type: none"> • Complete range of adaptors and accessories
	Series 5000 Quick release couplings	Nickel Plated Brass	BSPP Threads and hose barb Nominal diameter: 5 and 7mm	Quick couplings	<ul style="list-style-type: none"> • High flow and robust design • Compatible with market standards • Mini versions available
	Series 6000 Single seal super-rapid fittings	Nickel Plated Brass	Metric and imperial tube BSPT, BSPP Metric, UNF, NPTF threads	Push-In connection for plastic tubing	<ul style="list-style-type: none"> • Multipurpose fitting • Perfect choice for Mobile Automation • Single seal, collet design
	Series HP6000 Single seal super-rapid fittings	Nickel-plated brass	Metric parallel and tapered, ISO7 BSPT, ISO-228 BSPP	Push-In connection for lubrication tubing	<ul style="list-style-type: none"> • Series 6000 based for lubrication and greasing • Single seal, collet design
	Series 7000 Single seal super-rapid fittings	Nickel plated brass + Technopolymer body	Metric and imperial tube BSPT, BSPP Metric, UNF, NPTF threads	Push-In connection for plastic tubing	<ul style="list-style-type: none"> • Multipurpose fitting • Perfect choice for Mobile Automation
	Series 8000/H8000 Dual seal super-rapid fittings	Nickel-plated brass	BSPP (G1/8, G1/4, G3/8, G1/2)	Push-in connection with protection for extreme environments	<ul style="list-style-type: none"> • High performance • Dual seal • Spatter protection
	Series 9000 Dual seal air brake fittings	Brass	Metric tube Metric (ISO965) and Tapered NPTF (ANSI B1.20.3) threads	Push-In connection for air brake tubing	<ul style="list-style-type: none"> • Compact brass air brake fitting • Dual seal, collet design • Metric tube interface • TÜV certified • IATF 16949
	Series ND Single seal airbrake fittings	Nickel Plated Brass	Imperial tube UNF and NPTF threads	Push-In connection for air brake tubing	<ul style="list-style-type: none"> • Inch air brake fitting • Single seal, collet design • Meets FMVSS and SAE requirements

For further detailed information on our product range, please visit our website or contact our sales team.



Scan the QR Code

Contacts

Camozzi Automation S.p.A.

Società Unipersonale
Via Eritrea, 20/I
25126 Brescia
Italy
Tel. +39 030 37921
marketing@camozzi.com

Customer Service

Tel. +39 030 3792790
service@camozzi.com

Export Department

Tel. +39 030 3792253
sales@camozzi.com

